

Uniclass Pr_35_57_11_26
CI/SfB (71.3) X

BARRIER MATTING SYSTEMS

PRIMARY, HYBRID AND SECONDARY MATTING

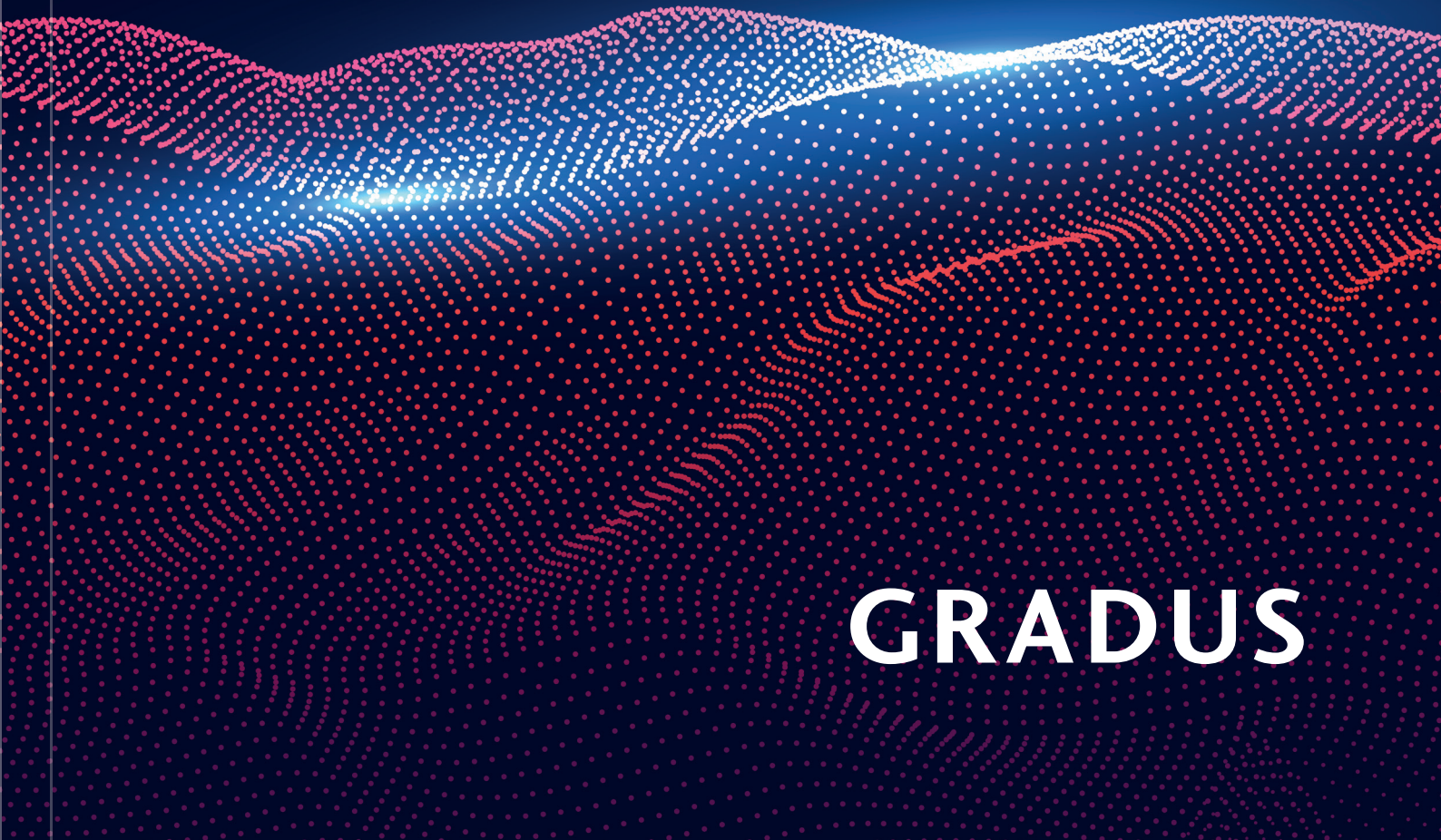

GRADUS

GRADUS

Our products are installed in prestigious buildings in both UK and International markets. With customers ranging from designers & architects to contractors and building owners and with clients such as Marks & Spencer, Virgin and BMW you can trust Gradus to provide products that work.



The Gherkin, London, England

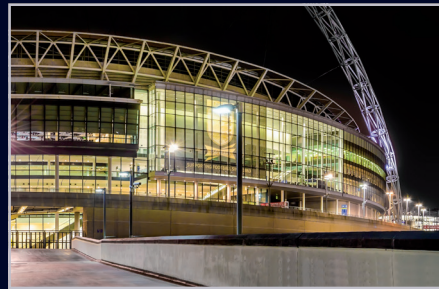

Wembley Stadium, London, England



Hong Kong International Airport



Marina Bay Sands Resort, Singapore



Royal Caribbean Cruise Ship



The Christie, Manchester, England



Burj Al Arab, Dubai, UAE



Eiffel Tower, Paris, France

Contents

NEW Product Update	2
Why Gradus	4
Primary Barrier Matting	
Why use barrier matting	8
Choosing the correct barrier matting	9
Where to use barrier matting	12
Primary Barrier Matting	
Primary Barrier Matting Product Selection Guide	16
Esplanade 9000	18
Esplanade 8500	20
Esplanade 6000	22
Esplanade 5000	24
Esplanade 1500	26
Esplanade 1000	28
Topguard	30
Topguard FR	32
Tyreguard	34
Hybrid Barrier Matting	
Hybrid Barrier Matting Product Selection Guide	36
Access 6000 & 5000	38
Mat-in-a-Box 6000 & 5000	40
Mat-in-a-Box 1550	42
Secondary Barrier Matting	
Secondary Barrier Matting Product Selection Guide	44
Boulevard Stripe	46
Boulevard 7000	48
Boulevard 6000	50
Boulevard 5000	52
Boulevard 1500	54
Accessories	
Installation Accessories	56
Matting Accessories	58
Services	
Manufacturing	64
Project Management & Installation	65
Specification Guidelines	
<i>Factors to consider when specifying a mat</i>	66
<i>The Building Regulations and British Standards</i>	68
Cleaning & Maintenance Guidelines	72
The Gradus Knowledge CPD & Seminar	73
NEW Fundamentals	74

NEW

Esplanade - Bronze Anodised Finishes

Esplanade offers a wide choice of solutions for different building applications and types of traffic. Selected Esplanade products are now available in a choice of three new bronze anodised finishes, which when combined with our wide choice of wiper options, provide an attractive addition to many interior settings.



Below are examples of bronze finishes combined with carpet wipers. Other combinations are available.

Three bronze finishes are available: Light Bronze, Mid Bronze and Dark Bronze.

Bronze finishes are available in the following Esplanade products:

- *Esplanade 8500* (see page 20)
- *Esplanade 6000* (see page 22)
- *Esplanade 5000* (see page 24)

Esplanade 5000 Light Bronze with Redpoll wiper



Esplanade 8500 Mid Bronze with Grey wiper

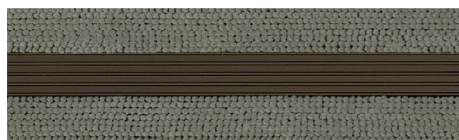

Esplanade 6000 Dark Bronze with Atlantic wiper

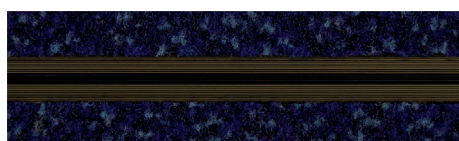

NEW

Esplanade 1500 - 12mm

Available March 2022

Esplanade 1500 combines a choice of polypropylene wipers from the Boulevard 1500 range, or black pvc scraper wipers, with an aluminium base and pvc bridging strips that provide additional strength. Now available with a 12mm gauge for greater versatility. Esplanade 1500 provides a perfect solution for medium traffic applications. See page 26 for details.

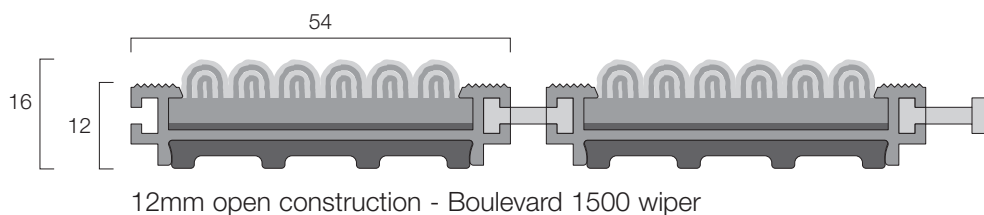

NEW

Mat-in-a-Box

Mat-in-a-Box is a modular barrier matting system that is quick and easy to install. Now available with a new Glacier (grey) base option that can be combined with wipers from either Boulevard 6000, Boulevard 5000 or Boulevard 1500 to provide an attractive and functional solution. See pages 40 and 42 for details.

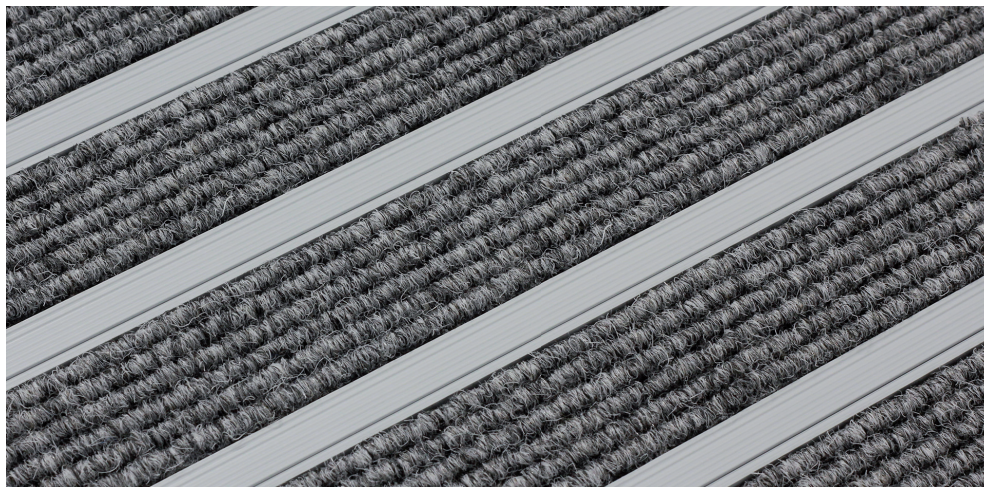

Why Gradus

Gradus offers an extensive range of barrier matting systems, providing an effective barrier against dirt and moisture at entrances, access points and circulation areas.

Correct specification helps to reduce slip accidents, increase the life cycle of surrounding floorcoverings and reduce cleaning and maintenance costs.

All our products are designed to ensure the correct balance between safety, performance and aesthetics and are suitable for a wide variety of contract applications.

Services

The Gradus Knowledge:

CPD - Gradus offers comprehensive RIBA assessed CPD seminars covering specification, legislation, safety, performance and aesthetics.

Seminar - An informal opportunity for Gradus to bring an exhibition of products directly to you. Flexible and informative, they can be arranged at a date and time to suit you. See page 73 for more information.

Project Management & Installation

A full project management and on-site installation service for primary entrance matting. See page 65 for more information.

Website

Visit www.gradus.com to access all of our products and services.

5 Day Manufacturing Service

Available for Esplanade 9000, Esplanade 8500, Esplanade 6000, Esplanade 5000, Esplanade 1500, Esplanade 1000, Topguard, Topguard Plain, Tyreguard, Access 6000, Access 5000, Mat-in-a-Box 6000 & Mat-in-a-Box 5000 on all orders up to 20m².
T&Cs apply see page 64.

Samples

Call Gradus or build a design board online and get all the samples you need within 24 hours.

Tel: 01625 428922
or email: imail@gradus.com





Quality

- All matting products are warranted against material and manufacturing defects under normal use and service, subject to materials being installed and maintained to Gradus recommendations. Warranty details can be found on individual product pages and on the charts on pages 16-17, 36-37 and 44-45. Additional terms & conditions apply - details available upon request.
- ISO 9001 Quality Management accredited company
- ISO 45001 Occupational Health & Safety

Design

- Safety: matting helps to reduce slips, trips and falls caused by wet flooring in line with the latest guidelines
- Performance: extensive research and testing ensures durability and appearance retention throughout a product's life
- Aesthetics: primary barrier mats can be manufactured to shapes and sizes to complement floor plans of entrances to buildings
- In-house product design and development

Sustainability

- ISO 14001 Environmental Management accredited company
- Our pledge is 'To meet our present business needs without compromising our long term future'
- We have a firm set of environmental objectives allowing us to focus on raw material selection, legislation, waste reduction, training and recycling



REACH

- REACH stands for Registration, Evaluation, Authorisation and Restriction of Chemicals. As of 1 January 2021 the UK REACH and the EU REACH regulations operate independently from each other.
- Gradus products do not contain any substances currently classified as Substances of Very High Concern (SVHC) at a concentration greater than 0.1% as declared against both the EU and UK Candidate Lists.
- If you have any specific concerns regarding the composition of a particular product, contact Gradus Technical Support.

Knowledge

- Member of the Contract Flooring Association (CFA)
- Registered member of the RIBA CPD Providers Network
- Technical Support
- Member of NBS Plus
- Network of trained specification consultants





Why use Barrier Matting

Increase Public Safety



According to the Health & Safety Executive, 90% of slip accidents in public buildings occur on wet floors.

An effective matting system can reduce the amount of dirt and moisture tracked into a building by up to 90%, helping to reduce such slip accidents.

Remove Dirt & Moisture



More than 70% of dirt and moisture in buildings is tracked in by pedestrian and wheeled traffic.

An effective matting system removes and retains dirt and moisture, improving the appearance of internal floorcoverings and preventing unnecessary replacements.

Reduce Maintenance Costs



On-going cleaning & maintenance is the largest cost in the lifecycle of any floorcovering. An effective entrance mat will reduce the amount of dirt that is tracked into a building therefore reducing maintenance costs and increasing the life of a building's floorcoverings.



ECONYL® Regenerated Solution Dyed Nylon is produced using nylon waste which is recovered from oceans and from landfill. Waste such as fishing nets, fabric scraps, carpet and industrial plastic is recovered, sorted and cleaned. Through a regeneration and purification process, the nylon waste is recycled back into its original purity. ECONYL® Regenerated Solution Dyed Nylon is processed into carpet yarn and used to manufacture several of our matting ranges.

Choosing the Correct Barrier Matting

Step 1

Application

Volume & Type of Traffic

The volume of foot traffic as well as both the frequency and load weight of wheeled traffic will determine the type of mat required.

Foot Traffic



Heavy

More than 5,000 crossings per day

Examples - railway station, stadiums, airports, shopping centres, large hospitals, supermarkets & department stores



Medium

More than 500 crossings per day

Examples - offices, hospitals, schools, high street shops & hotels

Typical types of wheeled traffic

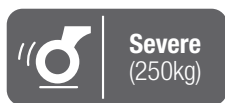

Severe
(250kg)



Forklift Truck



Cherry Picker



Heavy
(150kg)



Pallet Truck



Retail Cage

Note:
Illustrations are guidelines only. See product selection guide on pages 16-17 for further information



Medium
(100kg)



Shopping Trolley



Box Truck



Baggage Trolley



Light
(50kg)



Shopping Trolley



Suitcase



Wheelchair

The weights shown are per wheel. See notes on product selection guide on page 16 for more information.

Other factors to consider:

- Consider the environment immediately outside the building as this can affect the type, length (going) and performance of mat you select e.g. adjacent to turfed area, exposed entrance, entrance protected by canopy etc.
- Different entrances in a building may have different types and volumes of traffic, therefore more than one matting solution may be required in a building e.g. main and secondary entrances or main and service entrances.
- When specifying aluminium entrance mats consideration should be given to the type and amount of lighting and/or glass atriums as this may lead to visual distortion or strobing in certain circumstances. To minimise this effect avoid combining silver or mill finish aluminium with dark wipers. In some circumstances, black anodised aluminium and black wipers can be combined to minimise this effect.

Step 2

Type & Performance of Matting

Type of Matting - Primary, Hybrid or Secondary

Primary Barrier Matting - the first point of contact, used both externally and internally dependent on mat type and application. Available in a choice of heights to suit matwell depth or for surface mounting. (See zones 1 & 2 on pages 12-13 for more information). Primary barrier matting is usually supplied as a made to measure solution.

Hybrid Barrier Matting - the first point of contact used internally. Available in a choice of heights to suit matwell depth or for surface mounting. (See zone 2 on page 13 for more information). Hybrid barrier matting is easy to install and usually cut to fit on-site.

Secondary Barrier Matting - is made from high performance textiles and is often used in conjunction with a primary or hybrid mat to provide additional performance. Secondary barrier matting can be used as a stand-alone solution in some circumstances as well as in other areas of a building such as circulation areas. (See zones 3 & 4 on pages 12-13 for more information)

Type of Matting - Open or Closed Construction

Open Construction - (Fig.1) incorporates spaces allowing dirt and moisture to fall through in to the matwell below which can be lifted intermittently to remove the debris as well as for deep cleaning the mat itself.

Closed Construction - (Fig.2) dirt and moisture remain on the surface of the mat and can be removed by regular cleaning in addition to periodic deep cleaning of the mat itself.

Open Construction

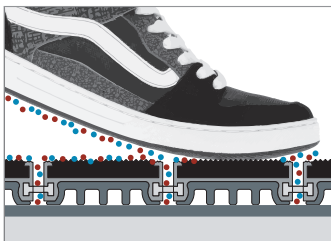

Fig.1 - Linking strips are interspersed with holes

Closed Construction

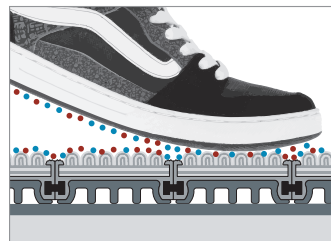

Fig.2

Performance of Matting - Wiper Options

The type and amount of wiper material will affect the level of dirt and moisture that is removed from foot and wheeled traffic.

Moisture & Dirt Removal



Wiper Options

Double Wiper Configuration

Esplanade 9000, Esplanade 8500, Topguard, Topguard FR & Tyreguard

Single Wiper Configuration

Esplanade 6000, Esplanade 5000, Access 6000, Access 5000, Mat-in-a-Box 6000 & Mat-in-a-Box 5000

Single Wiper Configuration

Esplanade 9000, Esplanade 8500, Topguard, Topguard FR, Tyreguard, Esplanade 1500, Esplanade 1000 & Mat-in-a-Box 1550

Note: Plain / pvc wipers provide a scraping action only.
See product selection chart on pages 16-17 and individual product pages for further information.

Step 3

Amount of Matting

Width and length of matting

Width - matting should cover the entire entrance of a building, including side entrances so that traffic cannot enter without passing over the mat.

Length (Going) - critical to the function of the mat the length will vary dependent on volume of traffic crossing the mat along with consideration to peak times of traffic flow.

HSL (Health & Safety Laboratory) and EFSA (Entrance Flooring Systems Association) have provided the following guidance based on peak flow rates per hour. For more information see page 66.

Applications	People Per Hour	Minimum Length
Low	78	3-4 metres
Medium	400	6-7 metres
High	800	8-10 metres

Note: It is not always possible to fit the correct amount of primary barrier matting - in these circumstances extending the amount of matting by using a secondary barrier mat will provide an ideal solution.



For more information on specifying the correct entrance barrier mat and for information on the guidance contained in Building Standards and British Standards please refer to specification guidelines on pages 66-71.

Gradus are able to provide a full consultation and advice service on selecting the correct barrier matting system - please call Technical Support on **01625 428922** to arrange a face to face meeting with a specification expert.

Where to use Barrier Matting

An effective barrier matting system, when correctly specified, will help to minimise the risk of slip accidents caused by wet flooring and lower maintenance costs by significantly reducing the amount of dirt and moisture tracked into a building. Barrier matting can not only be used at a building's entrance and access points but also in other areas that are subject to increased risk of soiling and heavy wear. In many cases the optimum performance is achieved by combining different types of barrier matting.

The illustration below is designed to act as a guide to show some of the areas of a building that are at risk. These are divided into zones, which are referred to throughout the catalogue.



Zone 1 Exterior Entrances & Access Points

Primary Barrier Matting

Products:	page
Esplanade 9000	18
Esplanade 8500	20
Esplanade 6000	22
Esplanade 5000	24
Esplanade 1500	26
Esplanade 1000	28
Topguard	30

- Removes excess dirt prior to entering a building using a scraper wiper
- Increases the effectiveness of internal primary, hybrid and secondary matting
- Ideal in heavy traffic areas



Zone 4 Other Areas

Products:	page
Boulevard Stripe	46
Boulevard 7000	48
Boulevard 6000	50
Boulevard 5000	52
Boulevard 1500	54

Secondary Barrier Matting

- Removes and retains dirt and moisture to prevent ingress to adjacent floorcoverings
- Ideal for use in internal areas subject to a risk of spillage and soiling such as canteen / vending areas or breakout areas within an office environment
- Products are produced from high performance fibres that are suited to intense cleaning to ensure long life appearance retention. All products carry the additional protection of a wear warranty

Zone 4

Zone 3

Zone 3

Zone 3 Interior Circulation Areas and Some Interior Entrances & Access Points

Products:	page
Boulevard Stripe	46
Boulevard 7000	48
Boulevard 6000	50
Boulevard 5000	52
Boulevard 1500	54

Secondary Barrier Matting

- Removes and retains dirt and moisture to prevent ingress to adjacent floorcoverings
- Often used in conjunction with Zone 2 primary entrance mats to create additional protection for surrounding floorcoverings. Can, in some circumstances, be used as stand alone entrance barrier matting
- Ideal for use in areas of heavy traffic and heavy wear such as staircases, reception areas, lift lobbies and internal entrances such as factory to office areas etc. **Note:** Boulevard Stripe and Boulevard 7000 are not recommended for use on staircases
- Offers excellent appearance retention properties when cleaned in accordance with Gradus recommended cleaning methods. All products carry the additional protection of a wear warranty
- Boulevard 6000 & Boulevard 5000 are available in a choice of broadloom or tile options

Zone 2 Interior Entrances & Access Points

Primary Barrier Matting & Hybrid Barrier Matting

Products:	page
Esplanade 9000	18
Esplanade 8500	20
Esplanade 6000	22
Esplanade 5000	24
Esplanade 1500	26
Esplanade 1000	28
Topguard	30
Topguard FR	32
Tyreguard	34
Access 6000 & 5000	38
Mat-in-a-Box 6000 & 5000	40
Mat-in-a-Box 1550	42

- Removes and retains dirt and moisture to prevent ingress to adjacent floorcoverings through a combination of scraper and textile wipers
- Available with a choice of wipers that offer excellent appearance retention when cleaned in accordance with Gradus recommendations
- Available in a choice of open and closed construction and in different gauges to suit both recessed and surface mounted options
- Available to suit varying types and volumes of traffic



Primary Barrier Matting

A collection of barrier matting products ideal for use at both internal and external entrance and access points. Products are available in a choice of formats to suit varying types and volumes of traffic.





Gradus offer a full project management and on-site installation service for all primary entrance mats. Full details can be found on page 65



Most primary matting products are available on a 5 day manufacturing service for orders up to 20m². Full details can be found on page 64

Primary barrier matting is often used in conjunction with a secondary barrier mat to provide a total matting solution.

Primary Barrier Matting Product Selection Guide

PRODUCT	FINISH	PAGE	WHERE TO USE BARRIER MATTING <i>(See pages 12-13)</i>		 FOOT TRAFFIC		 WHEELED TRAFFIC ¹ (Per wheel)		
			ZONE 1 (Plain/Pvc wiper)	ZONE 2 (Textile wiper)	HEAVY	MEDIUM	SEVERE (250kg)	HEAVY (150kg)	MEDIUM (100kg)
Esplanade 9000	Mill Finish Aluminium	18	✓	✓	✓		✓		
Esplanade 8500	Silver Anodised Aluminium	20		✓	✓			✓	
	Black and Bronze Anodised Aluminium ⁴	20		✓		✓			✓
	Mill Finish Aluminium	20	✓		✓			✓	
Topguard	Mill Finish Aluminium and Brass	30	✓ <i>Aluminium only</i>	✓	✓			✓	
Topguard FR	Mill Finish Aluminium	32		✓	✓			✓	
Tyreguard	Mill Finish Aluminium	34		✓	✓			✓	
Esplanade 6000	Mill Finish Aluminium	22	✓	✓	✓			✓ <i>Closed Construction</i>	✓ <i>Open Construction</i>
	Bronze Anodised Aluminium ⁴	22		✓		✓			✓
Esplanade 5000	Mill Finish Aluminium	24	✓	✓	✓			✓ <i>Closed Construction</i>	✓ <i>Open Construction</i>
	Bronze Anodised Aluminium ⁴	24		✓		✓			✓
Esplanade 1500	Mill Finish Aluminium	26	✓	✓		✓			✓
Esplanade 1000	Mill Finish Aluminium	28	✓	✓		✓			✓

Notes:

- ¹ All primary entrance barrier mats are independently tested to the weights specified using a four wheeled trolley with fixed 150 x 45mm hard rubber wheels to a minimum of 30,000 passes. eg 250kg per wheel = 1000kg over 4 wheels
- ² Manufacturing and material defects warranty. Warranty is subject to type of application, installation and on-going cleaning & maintenance being in accordance with Gradus recommendations. Additional terms & conditions apply - details available upon request.
- ³ Typical applications are a guide only. Attention should be paid to the performance characteristics of each mat type in conjunction with an assessment of the requirements of the particular application.
- ⁴ Anodised finishes provide an aesthetic solution and may help reduce visual distortion when used in brightly lit areas and / or glass atriums.

WIPER OPTIONS (See page 10)								TYPICAL APPLICATIONS ³	WARRANTY ²
 MOISTURE & DIRT REMOVAL			PLAIN / PVC (Scraper action only)	CONSTRUCTION (See page 10)					
SINGLE		DOUBLE		CLOSED	OPEN	SCRAPER			
HIGH	MEDIUM	HIGH							
		✓	✓	✓	✓		Airports, railway stations, supermarkets with heavy wheeled traffic	10 Years	
		✓	✓		✓	✓	Airports, railway stations, supermarkets & sports stadiums	10 Years	
		✓	✓		✓	✓	Medium foot and wheeled traffic areas only	7 Years	
				✓	✓		Airports, railway stations, supermarkets & sports stadiums	10 Years	
		✓	✓	✓	Aluminium only	✓	Airports, railway stations, supermarkets & sports stadiums	10 Years	
		✓	✓			✓	Airports, railway stations, supermarkets & sports stadiums	10 Years	
		✓	✓			✓	Airports, railway stations, supermarkets & sports stadiums	10 Years	
	✓			✓		✓	Large hospitals, offices, schools & department stores	10 Years	
	✓					✓	Large hospitals, offices, schools & department stores	7 Years	
	✓			✓		✓	Large hospitals, offices, schools & department stores	10 Years	
	✓					✓	Large hospitals, offices, schools & department stores	7 Years	
		✓		✓		✓	Schools, offices & high street shops	10 Years	
		✓		✓		✓	Schools, offices & high street shops	5 Years	

Esplanade 9000



Zones 1 & 2:

Exterior & Interior Entrances & Access Points

Esplanade 9000 is constructed from rubber wipers and aluminium scraper linking strips which are held together with galvanised steel wires. The rubber wipers are available either plain or interwoven with grey polyester fibres. When installed as a true rectangle or a square Esplanade 9000 can be reversed to extend the product's life. For a complete matting solution Esplanade 9000 can also be used with Boulevard secondary barrier matting.

Typical applications:

Airports, railway stations, supermarkets with heavy wheeled traffic



Product Information

See primary matting product selection guide - **pages 16-17**



Note - plain wiper - scraper action only - for exterior use.

- Available in open (5mm) or closed construction
- Available with single or double wipers
- Can be reversed when installed as a true rectangle or a square
- Supplied with edging strips and divider bars (see page 57)
- Flammability - BS EN 13501-1 Class Cfl-s2
- Slip-resistance (HSL ramp test) - low risk of slip
- Can be manufactured to most shapes on approval of a template
- Warranty - 10 years

12mm closed construction - single wiper

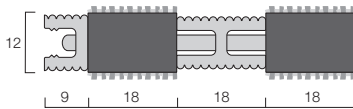

18mm open construction - double wiper

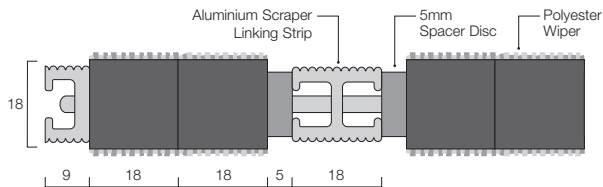

Configuration examples for all products visit www.gradus.com.
 Profiles: Dimensions shown are nominal. Illustrations not to size.
 Products subject to minor design alterations without notice.

Typical Installation

Esplanade 9000 12mm open construction with double grey polyester wipers. Recessed in a matwell.

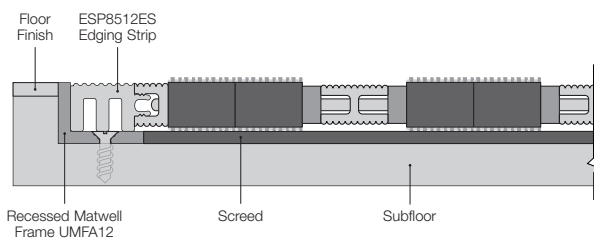

For installation accessories see pages 56-57.
 For matwell frames and matting accessories see pages 58-63.

Configurations

Closed construction
 (shown with grey single wipers)

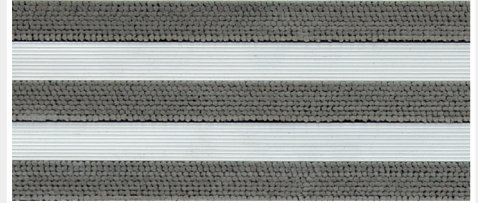

Closed construction
 (shown with grey double wipers)

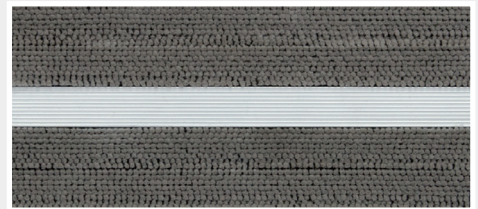

Open construction
 (shown with plain single wipers)

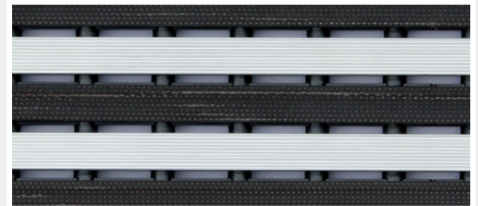

Aluminium Scraper Linking Strip

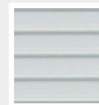

Mill Finish

Esplanade 8500



Zones 1 & 2:

Exterior & Interior Entrances & Access Points

Esplanade 8500 is constructed from rubber wipers and aluminium scraper linking strips which are held together with galvanised steel wires. The rubber wipers are available either plain or interwoven with polyester fibres in a choice of grey or black. The aluminium scraper linking strips are anodised for use in internal environments to help reduce glare/strobing in brightly lit areas and are available in a silver anodised finish for use with grey wipers and black or a choice of bronze anodised finishes for use with either black or grey wipers. The scraper linking strips for use with plain wipers are mill finished aluminium. For a complete matting solution Esplanade 8500 can also be used with Boulevard secondary barrier matting.

Typical applications:

Airports, railway stations, supermarkets & sports stadiums.

Note - black & bronze anodised finishes medium foot & medium wheeled traffic areas only.



Product Information

See primary matting product selection guide - **pages 16-17**

12mm
Gauge

18mm
Gauge

reversible

 Heavy

 Heavy

 Medium

 silver anodised finish

 mill finish

 black & bronze anodised finish

 Heavy
(150kg)

 Heavy
(150kg)

 Medium
(100kg)

 silver anodised finish

 mill finish

 black & bronze anodised finish

 High

 Medium

double wiper single wiper

Note - plain wiper - scraper action only - for exterior use.

- Available in open (5mm) or closed construction
- Available with single or double wipers
- Can be reversed when installed as a true rectangle or a square
- Supplied with edging strips and divider bars (see page 57)
- Flammability - BS EN 13501-1 Class CfI-s2
- Slip-resistance (HSL ramp test) - low risk of slip
- Can be manufactured to most shapes on approval of a template
- Warranty - silver anodised & mill finish aluminium 10 years, black and bronze anodised aluminium finish 7 years

12mm closed construction - single wiper

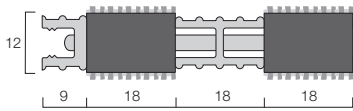

18mm open construction - double wiper

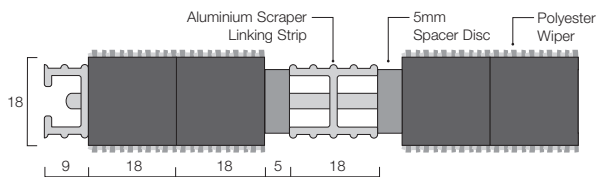

Typical Installation

Esplanade 8500 12mm open construction with double grey polyester wipers and silver anodised aluminium scraper linking strips. Recessed in a matwell.

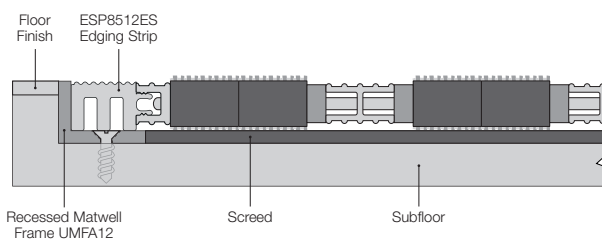

For installation accessories see pages 56-57.

For matwell frames and matting accessories see pages 58-63.

Configurations

Closed construction
(shown with grey single wipers and silver anodised aluminium scraper linking strips)

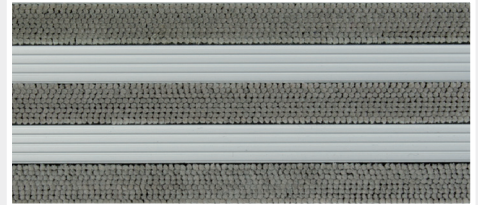

Closed construction
(shown with black double wipers and black anodised aluminium scraper linking strips)



Open construction
(shown with plain single wipers and mill finish aluminium scraper linking strips)

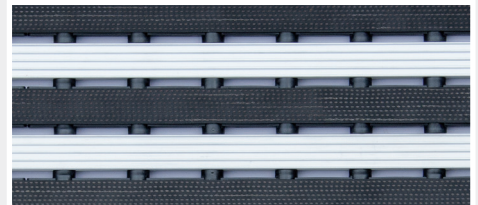

Closed construction
(shown with grey single wipers and mid bronze anodised aluminium scraper linking strips)

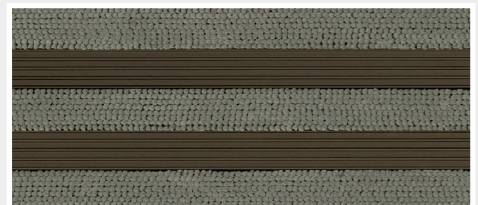

Aluminium Scraper Linking Strip Options

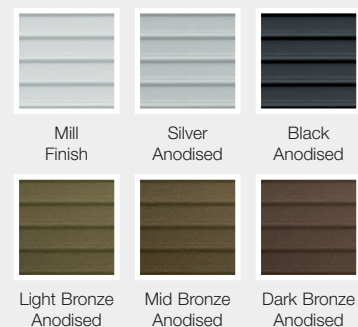

NEW

Esplanade 6000



Zones 1 & 2:

Exterior & Interior Entrances & Access Points

Esplanade 6000 is constructed from either ECONYL® regenerated solution dyed nylon wipers from the Boulevard 6000 range or black pvc scraper wipers. These are supported with an aluminium base with pvc bridging strips that provide additional strength and are combined with pvc linking strips. The aluminium base is available in a choice of mill finish or a choice of three bronze anodised finishes. The ECONYL® regenerated solution dyed nylon wipers provide excellent soil & moisture retention and are available in a choice of 8 colours. Esplanade 6000 coordinates with Boulevard 6000 for a complete entrance matting solution.

Typical applications:

Large hospitals, offices, schools & department stores.

Note - Open construction medium wheeled traffic areas only. Bronze anodised finish medium foot & wheeled traffic areas only (see page 16-17).



Product Information

See primary matting product selection guide - **pages 16-17**



Mill Finish



Anodised Finish



Note - pvc wiper - scraper action only - for exterior use.

- Available in open or closed construction
- Pvc linking strips available in black or grey (closed construction). A push-in hinge is available when installing Esplanade 6000 in restricted areas (see page 57)
- Supplied with edging strips and divider bars (see page 57)
- Flammability - BS EN 13501-1 Class Cfl-s1
- Slip-resistance (HSL ramp test) - low risk of slip
- Can be manufactured to most shapes on approval of a template
- Warranty - mill finish aluminium 10 years, bronze anodised 7 years

12mm closed construction - Boulevard 6000 wiper

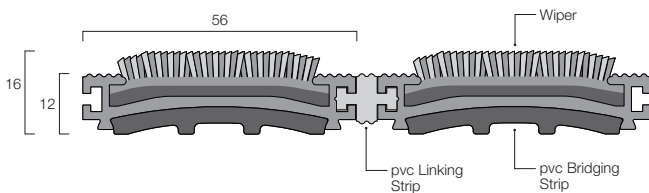

18mm open construction - pvc scraper wiper

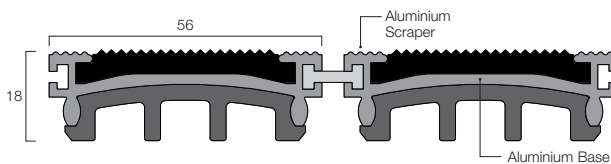

Configuration examples for all products visit www.gradus.com.
Profiles: Dimensions shown are nominal. Illustrations not to size.
Products subject to minor design alterations without notice.

Typical Installation

Esplanade 6000 18mm closed construction with Boulevard 6000 wipers. Recessed in a matwell.

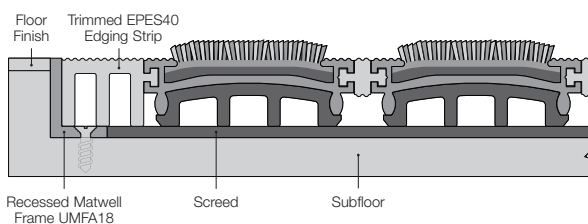

For installation accessories see pages 56-57.
For matwell frames and matting accessories see pages 58-63.

Configurations

Boulevard 6000 wiper colour options (refer to page 51 for more information)

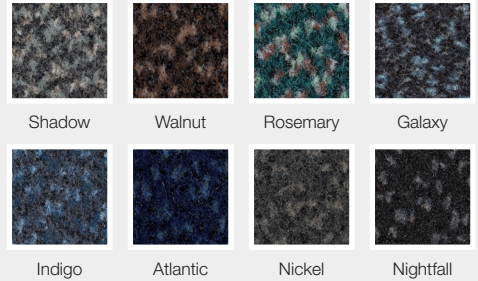

Closed construction (shown with Indigo wipers, black pvc linking strip & mill finish aluminium base)

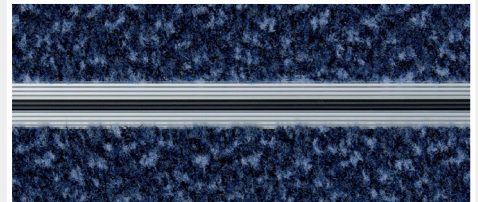

Open construction (shown with pvc scraper wipers & mill finish aluminium base)



Closed construction (shown with Atlantic wipers, black pvc linking strip & dark bronze anodised aluminium base)

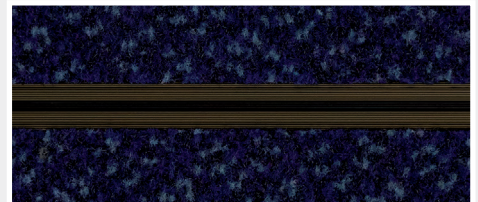

Aluminium Base Options

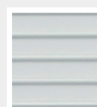

Mill Finish

NEW

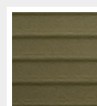

Light Bronze Anodised

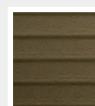

Mid Bronze Anodised

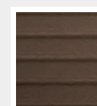

Dark Bronze Anodised

Esplanade 5000



Zones 1 & 2:

Exterior & Interior Entrances & Access Points

Esplanade 5000 is constructed from either ECONYL® regenerated solution dyed nylon wipers from the Boulevard 5000 range or black pvc scraper wipers. These are supported with an aluminium base with pvc bridging strips that provide additional strength and are combined with pvc linking strips. The aluminium base is available in a choice of mill finish or a choice of three bronze anodised finishes. The ECONYL® regenerated solution dyed nylon wipers provide excellent soil & moisture retention and are available in a choice of 9 colours. Esplanade 5000 coordinates with Boulevard 5000 for a complete entrance matting solution.

Typical applications:

Large hospitals, offices, schools & department stores.

Note - Open construction medium wheeled traffic areas only. Bronze anodised finish medium foot & wheeled traffic areas only (see page 16-17).



Product Information

See primary matting product selection guide - **pages 16-17**



Mill Finish



Anodised Finish



Note - pvc wiper - scraper action only - for exterior use.

- Available in open or closed construction
- Pvc linking strips available in black or grey (closed construction). A push-in hinge is available when installing Esplanade 5000 in restricted areas (see page 57)
- Supplied with edging strips and divider bars (see page 57)
- Flammability - BS EN 13501-1 Class Cfl-s1
- Slip-resistance (HSL ramp test) - low risk of slip
- Can be manufactured to most shapes on approval of a template
- Warranty - mill finish aluminium 10 years, anodised 7 years

12mm closed construction - Boulevard 5000 wiper

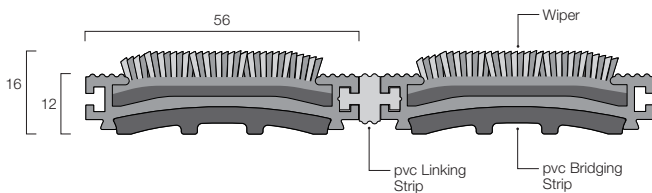

18mm open construction - pvc scraper wiper

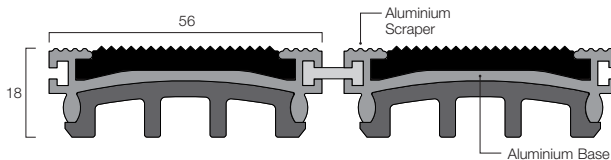

Configuration examples for all products visit www.gradus.com. Profiles: Dimensions shown are nominal. Illustrations not to size. Products subject to minor design alterations without notice.

Typical Installation

Esplanade 5000 18mm closed construction with Boulevard 5000 wipers. Recessed in a matwell.

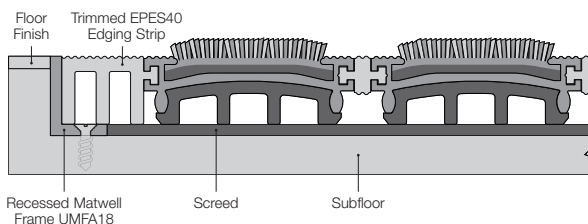

For installation accessories see pages 56-57.
For matwell frames and matting accessories see pages 58-63.

Configurations

Boulevard 5000 wiper colour options (refer to page 51 for more information)



Closed construction (shown with Corncrake wipers, grey pvc linking strip & mill finish aluminium base)

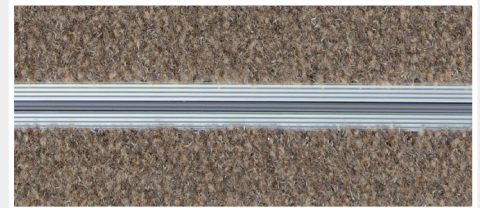

Open construction (shown with pvc scraper wipers & mill finish aluminium base)



Closed construction (shown with Redpoll wipers, black pvc linking strip & light bronze anodised aluminium base)



Aluminium Base Options

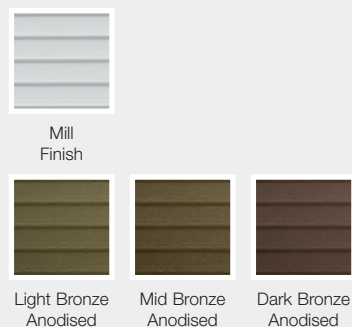

Esplanade 1500



Zones 1 & 2:

Exterior & Interior Entrances & Access Points

Esplanade 1500 is constructed from either 100% polypropylene wipers from the Boulevard 1500 range or black pvc scraper wipers which are supported with an aluminium base and pvc bridging strips that provide additional strength.

The 100% polypropylene wipers are available in a choice of 4 colours.

Esplanade 1500 coordinates with Boulevard 1500 for a complete entrance matting solution.

Typical applications:

Schools, offices & high street shops



Product Information

See primary matting product selection guide - **pages 16-17**



Note - pvc wiper - scraper action only - for exterior use.

- Available in open, closed or scraper construction
- Pvc linking strips: open construction - silver, scraper construction - black
- Supplied with edging strips and divider bars (see page 57)
- Flammability - BS EN 13501-1 Class Efl
- Slip-resistance (HSL ramp test) - low risk of slip
- Can be manufactured to most shapes on approval of a template
- Warranty - 10 years

NEW 12mm open construction - Boulevard 1500 wiper - (Available March 2022)

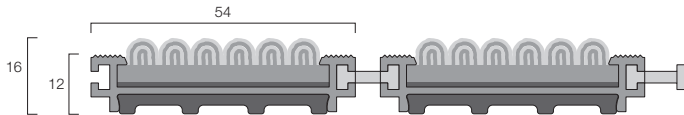

16.5mm closed construction - Boulevard 1500 wiper

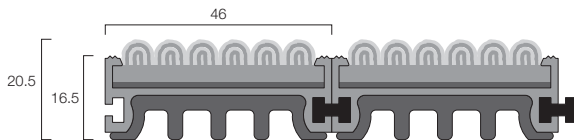

16.5mm open construction - pvc scraper wiper

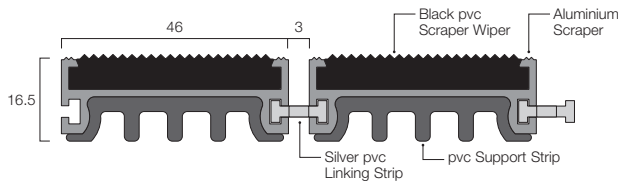

16.5mm scraper construction - Boulevard 1500 wiper

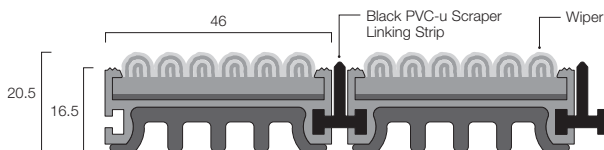

Configuration examples for all products visit www.gradus.com.
Profiles: Dimensions shown are nominal. Illustrations not to size.
Products subject to minor design alterations without notice.

Typical Installation

Esplanade 1500 open construction with Boulevard 1500 wipers.
Recessed in a Matwell.

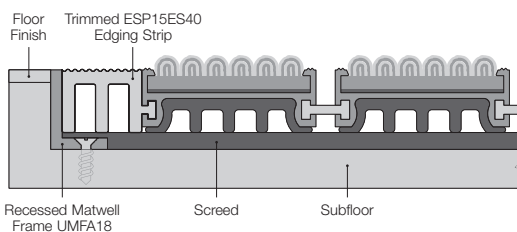

For installation accessories see pages 56-57.
For matwell frames and matting accessories see pages 58-63.

Configurations

Boulevard 1500 wiper colour options
(refer to page 55 for more information)

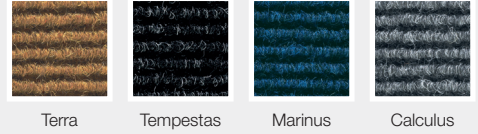

Closed construction
(shown with Terra wipers)

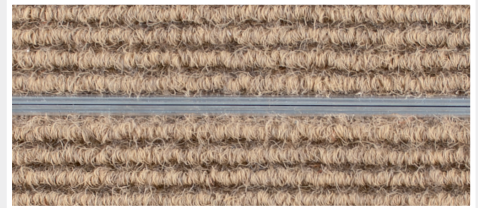

Open construction
(shown with pvc scraper wipers)



Esplanade 1000



Zones 1 & 2:

Exterior & Interior Entrances & Access Points

Esplanade 1000 is constructed from either ECONYL® regenerated solution dyed nylon wipers or black pvc scraper wipers which are supported with an aluminium base. The ECONYL® regenerated solution dyed nylon wipers are available in a choice of 4 colours and provide soil and moisture retention.

For a complete matting solution Esplanade 1000 can be combined with Boulevard secondary barrier matting.

Typical applications:

Schools, offices & high street shops



Product Information

See primary matting product selection guide - **pages 16-17**



Note - pvc wiper - scraper action only - for exterior use.

- Available in open or closed construction
- Supplied with edging strips and divider bars (see page 57)
- Flammability - BS EN 13501-1 Class Efl
- Slip-resistance (HSL ramp test) - low risk of slip
- Can be manufactured to most shapes on approval of a template
- Warranty - 5 years

12mm closed construction - solution dyed nylon wiper

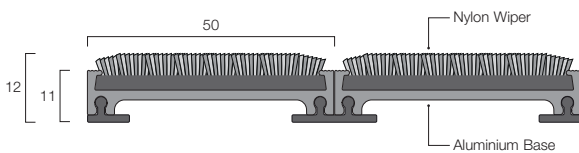

18mm open construction - pvc scraper wiper

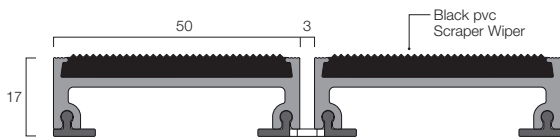

Configuration examples for all products visit www.gradus.com.
Profiles: Dimensions shown are nominal. Illustrations not to size.
Products subject to minor design alterations without notice.

Typical Installation

Esplanade 1000 18mm open construction with solution dyed nylon wipers. Recessed in a Matwell.

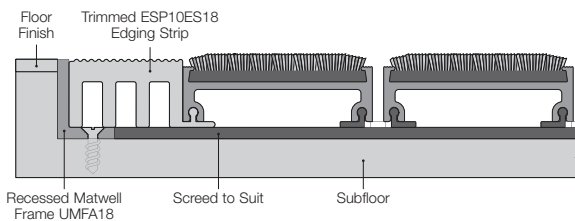

For installation accessories see pages 56-57.
For matwell frames and matting accessories see pages 58-63.

Configurations

Wiper colour options



Closed construction
(shown with Typhoon wipers)

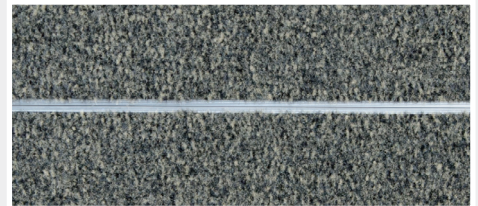

Open construction
(shown with pvc scraper wipers)





Zones 1 & 2:

Exterior & Interior Entrances & Access Points

Topguard is constructed from rubber wipers and scraper linking strips which are held together with galvanised steel wires. The rubber wipers are available either plain or interwoven with nylon fibres in a choice of grey or black. The scraper linking strips are available in either aluminium or brass. When installed as a true rectangle or a square Topguard can be reversed to extend the product's life. For a complete matting solution Topguard can also be used with Boulevard secondary barrier matting.

Typical applications:



Airports, railway stations, supermarkets & sports stadiums



Excludes Topguard with brass scraper linking strips

Product Information

See primary matting product selection guide - pages 16-17

12mm Gauge 18mm Gauge reversible



Heavy Heavy (150kg)





High Medium

double wiper single wiper

Note - plain wiper - scraper action only - for exterior use.

- Available in open (5mm) or closed construction
- Available with single or double wipers
- Can be reversed when installed as a true rectangle or a square
- Supplied with divider bars (see page 57)
- Slip-resistance (HSL ramp test) - low risk of slip
- Can be manufactured to most shapes on approval of a template
- Warranty - 10 years

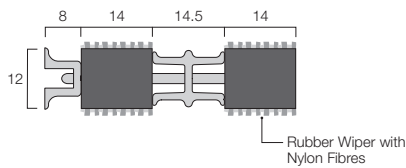
12mm closed construction - single wiper



18mm open construction - double wiper

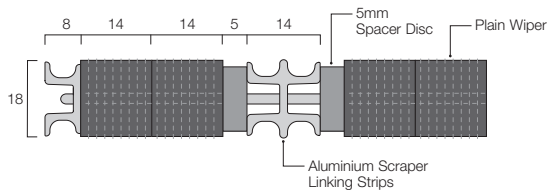

Configuration examples for all products visit www.gradus.com.
 Profiles: Dimensions shown are nominal. Illustrations not to size.
 Products subject to minor design alterations without notice.

Typical Installation

Topguard 12mm open construction with double grey nylon wipers and aluminium scraper linking strips. Recessed in a matwell.

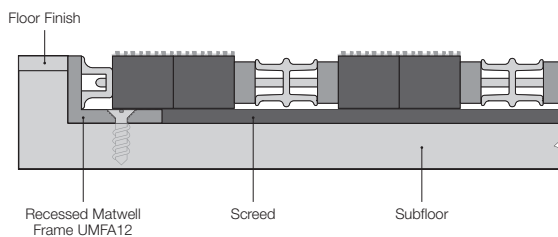

For installation accessories see pages 56-57.
 For matwell frames and matting accessories see pages 58-63.

Configurations

Closed construction (shown with grey single wipers)

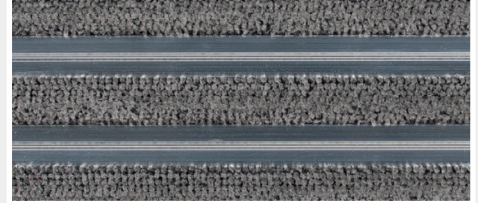

Open construction (shown with black single wipers)



Closed construction (shown with plain single wipers)

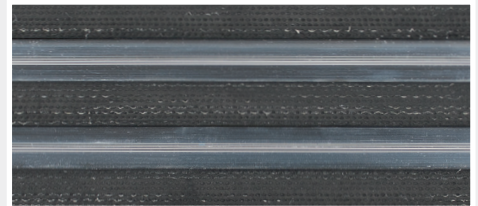

Scraper Linking Strip Options

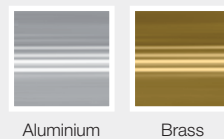

Plain wipers only available with aluminium scraper linking strips

Topguard® FR



Zone 2:

Interior Entrances & Access Points

Topguard FR is a fire rated primary barrier mat constructed from rubber wipers and aluminium scraper linking strips which are held together with galvanised steel wires. The rubber wipers are interwoven with grey nylon fibres. When installed as a true rectangle or a square Topguard FR can be reversed to extend the product's life.

For a complete matting solution Topguard FR can also be used with Boulevard secondary barrier matting.

Typical applications:

Airports, railway stations, supermarkets & sports stadiums



Product Information

See primary matting product selection guide - **pages 16-17**

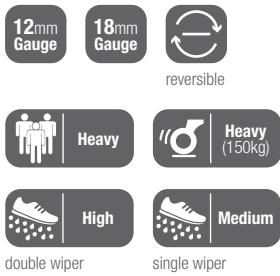

- Available in closed construction only
- Available with single or double wipers
- Can be reversed when installed as a true rectangle or a square
- Supplied with divider bars (see page 57)
- Flammability - BS EN 13501-1 Class Bfl-s1
- Slip-resistance (HSL ramp test) - low risk of slip
- Can be manufactured to most shapes on approval of a template
- Warranty - 10 years

12mm closed construction - single wiper

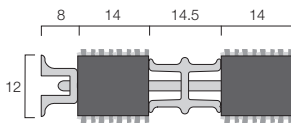

18mm closed construction - double wiper

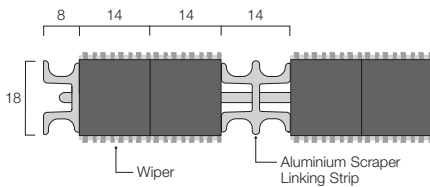

Configuration examples for all products visit www.gradus.com.
 Profiles: Dimensions shown are nominal. Illustrations not to size.
 Products subject to minor design alterations without notice.

Typical Installation

Topguard FR 18mm closed construction with double grey nylon wipers and aluminium scraper linking strips. Recessed in a matwell.

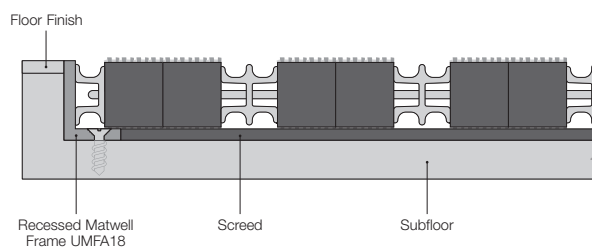

For installation accessories see pages 56-57.
 For matwell frames and matting accessories see pages 58-63.

Configurations

Closed construction
 (shown with grey single wipers)

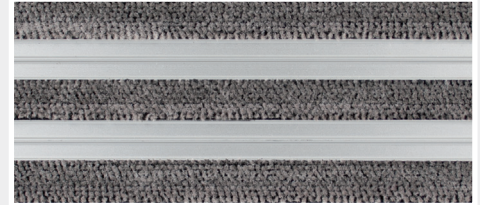

Scraper Linking Strips

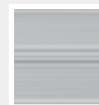

Aluminium

Tyreguard



Zone 2:

Interior Entrances & Access Points

Tyreguard is an ideal choice where the use of recycled materials is a key consideration. Tyreguard is constructed from 100% recycled rubber wipers and aluminium scraper linking strips which are held together with galvanised steel wires. Entirely manufactured from aeroplane tyres the rubber wipers are interwoven with alternate layers of textile and rubber. When installed as a true rectangle or a square Tyreguard can be reversed to extend the product's life. For a complete matting solution Tyreguard can also be used with Boulevard secondary barrier matting.

Typical applications:

Airports, railway stations, supermarkets & sports stadiums



Product Information

See primary matting product selection guide - **pages 16-17**

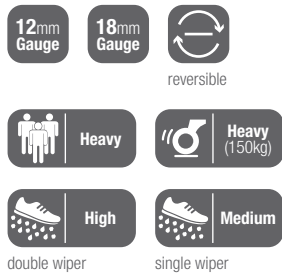

- Available in open or closed construction
- Available with single or double wipers
- Can be reversed when installed as a true rectangle or a square
- Supplied with divider bars (see page 57)
- Slip-resistance (HSL ramp test) - low risk of slip
- Can be manufactured to most shapes on approval of a template
- Warranty - 10 years

12mm closed construction - single wiper

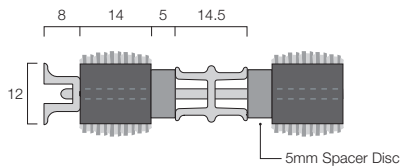

18mm closed construction - double wiper

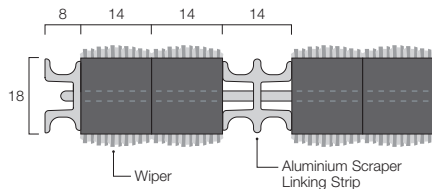

Configuration examples for all products visit www.gradus.com.
 Profiles: Dimensions shown are nominal. Illustrations not to size.
 Products subject to minor design alterations without notice.

Typical Installation

Tyreguard 18mm closed construction with double wipers and aluminium scraper linking strips. Recessed in a Matwell.

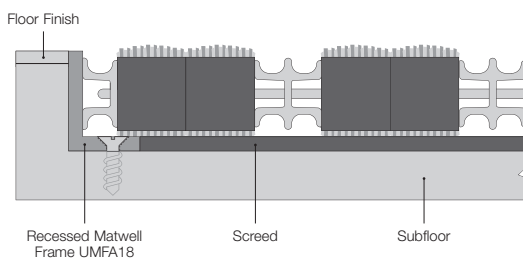

For installation accessories see pages 56-57.
 For matwell frames and matting accessories see pages 58-63.

Configurations

Closed construction
 (shown with single wipers)

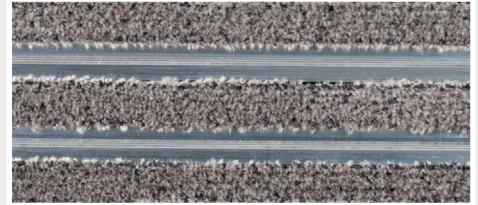

Scraper Linking Strips

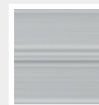

Aluminium

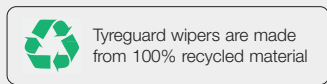

NOTE:

Wipers are made from 100% recycled material from aeroplane tyres, of which at least 50% is vulcanised rubber with the remainder being textile material. Due to the recycled content of the matting, there will be inconsistencies in the pile height and in the width and shading of the wipers. Some of these variations should become less apparent once the product has been installed for a period of time.





Hybrid Barrier Matting Product Selection Guide

PRODUCT	FINISH	PAGE	WHERE TO USE BARRIER MATTING (See pages 12-13)	 FOOT TRAFFIC	 WHEELED TRAFFIC ¹ (Per wheel)	
			ZONE 2 (Textile wiper)	MEDIUM	MEDIUM (100kg)	LIGHT (50kg)
Mat-in-a-Box 6000 & 5000	<i>PVC-u</i>	40	✓	✓	✓	
Mat-in-a-Box 1550	<i>PVC-u</i>	42	✓	✓	✓	
Access 6000 & 5000	<i>Rubber</i>	38	✓	✓		✓

Notes:

¹ All hybrid entrance barrier mats are independently tested to the weights specified using a four wheeled trolley with fixed 150 x 45mm hard rubber wheels to a minimum of 30,000 passes. eg 100kg per wheel = 400kg over 4 wheels.

² Manufacturing and material defects warranty. Warranty is subject to type of application, installation and on-going cleaning & maintenance being in accordance with Gradus recommendations. Additional terms & conditions apply - details available on request.

³ Typical applications are a guide only. Attention should be paid to the performance characteristics of each mat type in conjunction with an assessment of the requirements of the particular application.

Hybrid Barrier Matting

A range of modular barrier matting products ideal for use in interior entrances and access points. Hybrid barrier matting is quick and easy to install and can be cut and trimmed on site.



Most hybrid barrier matting products are available on a 5 day manufacturing service for orders up to 20m². Full details can be found on page 62.

Hybrid barrier matting is often used in conjunction with secondary barrier matting to provide a total matting solution.

WIPER OPTIONS <i>(See page 10)</i>				TYPICAL APPLICATIONS ³	WARRANTY ²
 MOISTURE & DIRT REMOVAL		CONSTRUCTION <i>(See page 10)</i>			
HIGH	MEDIUM	CLOSED			
✓		✓		Schools, offices & high street shops	7 Years
	✓	✓		Schools, offices & high street shops	5 Years
✓		✓		Smaller mat areas - schools, offices & high street shops	7 Years

Access® 6000 & 5000



Zone 2:

Interior Entrances & Access Points

Access 6000 & 5000 are constructed from ECONYL® regenerated solution dyed nylon wipers which are supported with a moulded rubber base. The wipers, which provide excellent soil and moisture retention, are available in a choice of colours from the Boulevard 6000 & 5000 ranges. Access is ideal for use where electronic tagging systems operate and is easy to cut and trim on-site. Access 6000 coordinates with Boulevard 6000 and Access 5000 coordinates with Boulevard 5000 for a complete matting solution.

Typical applications:

Smaller mat areas - schools, offices & high street shops



Product Information

See hybrid matting product selection guide - pages 36-37

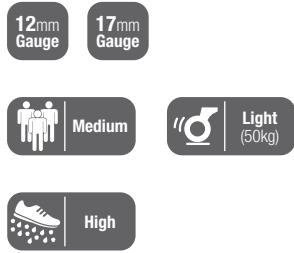

- Available with a black or grey rubber base
- Closed construction
- Provided in 0.5m x 2.0m modules and supplied oversized for shaping and trimming on-site
- Spacer strips are supplied to allow for minor movement within the mat and provide a neat finish (see page 57)
- Slip-resistance (HSL ramp test) - low risk of slip
- Flammability - BS 4790:1987 - rated low fire risk
- Tested for dimensional stability
- Warranty - 7 years

12mm

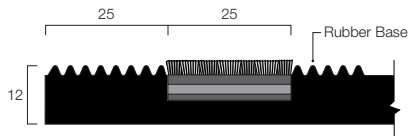

17mm

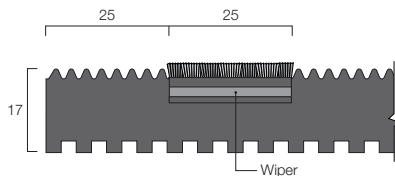

Configuration examples for all products visit www.gradus.com. Profiles: Dimensions shown are nominal. Illustrations not to size. Products subject to minor design alterations without notice.

Typical Installation

Access 6000 12mm with Boulevard 6000 wipers. Recessed in a matwell.

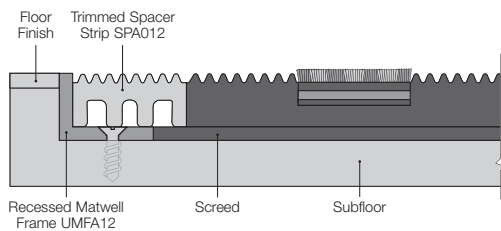

For installation accessories see pages 56-57. For matwell frames and matting accessories see pages 58-63.

Boulevard 6000 wiper colour options (refer to page 51 for more information)

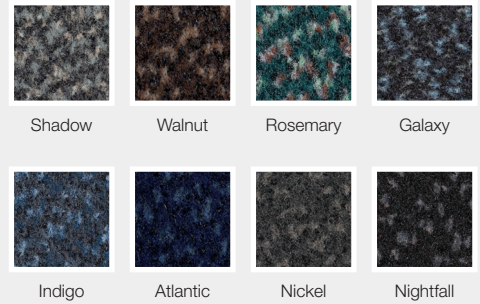

Boulevard 5000 wiper colour options (refer to page 53 for more information)



Access 6000 (shown with black base & Galaxy wipers)

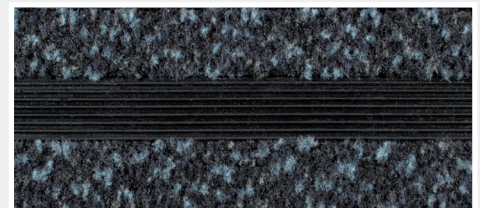

Access 5000 (shown with grey base & Redpoll wipers)



Mat-in-a-Box® 6000 & 5000



Zone 2:

Interior Entrances & Access Points

Mat-in-a-Box 6000 & 5000 is a modular barrier matting system that is quick and easy to install. The product is constructed from ECONYL® regenerated solution dyed nylon wipers which are supported with a PVC-u base available in either black or Glacier (grey). The wipers, which provide excellent soil and moisture retention are available in a choice of colours from the Boulevard 6000 & 5000 ranges. The individual sections clip together on-site for quick and easy assembly and the PVC-u base incorporates flexible pvc pads for noise reduction. Mat-in-a-Box 6000 coordinates with Boulevard 6000 and Mat-in-a-Box 5000 coordinates with Boulevard 5000 for a complete matting solution.

Typical applications:

Schools, offices & high street shops



Mat-in-a-Box® 6000 & 5000

Product Information

See hybrid matting product selection guide - **pages 36-37**



- Closed construction
- Supplied in components. Standard box contains 2 square metres (16 x 2m lengths), edging strip (1 x 2m), support piece (1 x 2m) and expansion strip (1 x 2m) - see page 57
- Individual sections clip together on-site for quick and easy assembly
- Slip-resistance (HSL ramp test) - low risk of slip
- Flammability - BS EN 13501-1 Class Cfl-s1
- Warranty - 7 years

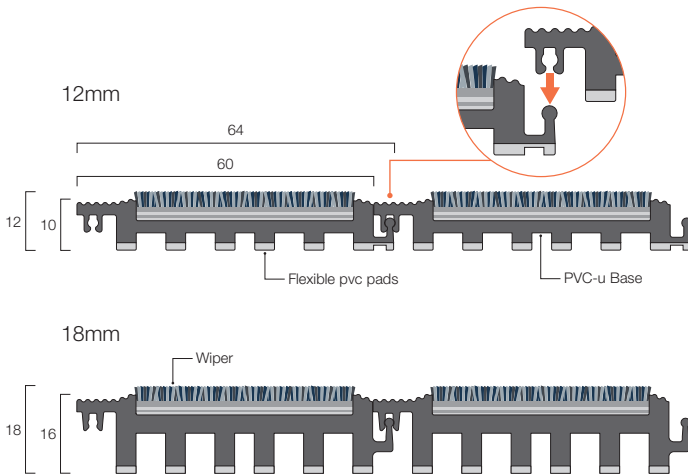

Configuration examples for all products visit www.gradus.com.
 Profiles: Dimensions shown are nominal. Illustrations not to size.
 Products subject to minor design alterations without notice.

Typical Installation

Shown recessed in a matwell.

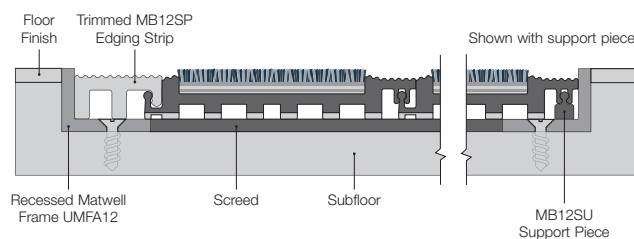

For installation accessories see pages 56-57.
 For matwell frames and matting accessories see pages 58-63.

Boulevard 6000 wiper colour options
 (refer to page 51 for more information)

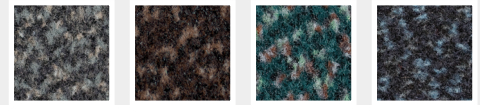

Shadow Walnut Rosemary Galaxy

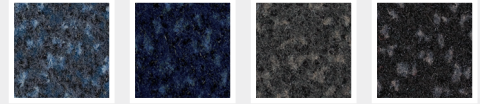

Indigo Atlantic Nickel Nightfall

Boulevard 5000 wiper colour options
 (refer to page 53 for more information)

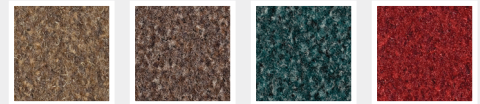

Corncrake Kestrel Shelduck Redpoll

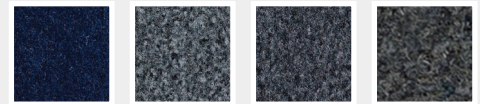

Swallow Cuckoo Moorhen Falcon

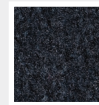

Jackdaw



Mat-in-a-Box 6000
 (shown with black base & Shadow wipers)



NEW Mat-in-a-Box 6000
 (shown with Glacier grey base & Indigo wipers)

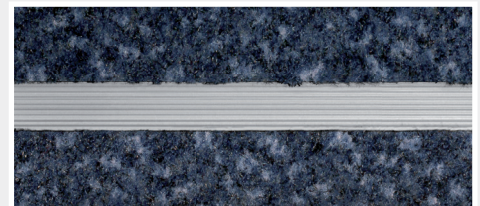

Mat-in-a-Box[®] 1550



Zone 2:

Interior Entrances & Access Points

Mat-in-a-Box 1550 is a modular barrier matting system that is quick and easy to install. The product is constructed from 100% polypropylene wipers which are supported with a PVC-u base available in either black or Glacier (grey). The wipers are available in 3 colours. The individual sections clip together on-site for quick and easy assembly and the PVC-u base incorporates flexible pvc pads for noise reduction. Mat-in-a-Box 1550 coordinates with Boulevard 1500 for a complete matting solution.

Typical applications:

Schools, offices & high street shops



Product Information

See hybrid matting product selection guide - **pages 36-37**



- Closed construction
- Supplied in components. Standard box contains 2 square metres (16 x 2m lengths), edging strip (1 x 2m), support piece (1 x 2m) and expansion strip (1 x 2m) - see page 57
- Individual sections clip together on-site for quick and easy assembly
- Slip-resistance (HSL ramp test) - low risk of slip
- Flammability - BS EN 13501-1 Class Efl-s1
- Warranty - 5 years

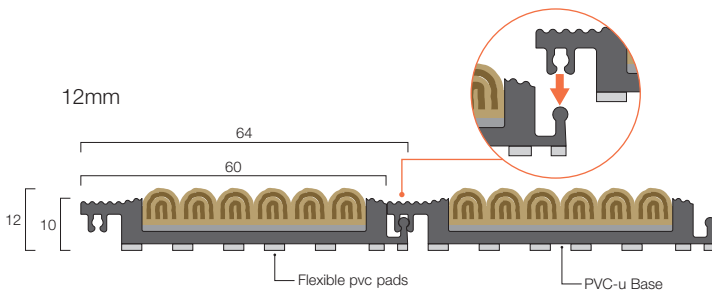

Configuration examples for all products visit www.gradus.com.
 Profiles: Dimensions shown are nominal. Illustrations not to size.
 Products subject to minor design alterations without notice.

Typical Installation

Shown recessed in a matwell.

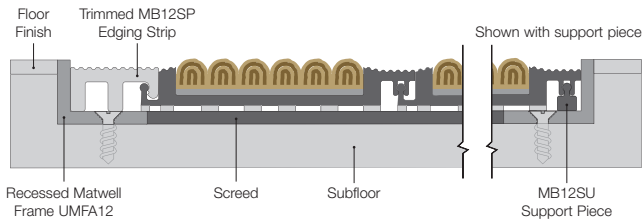

For installation accessories see pages 56-57.
 For matwell frames and matting accessories see pages 58-63.

Wiper colour options



Terra



Tempestatas



Calculus

Mat-in-a-Box 1550

(shown with black base & Tempestatas wipers)



NEW

Mat-in-a-Box 1550

(shown with Glacier grey base & Calculus wipers)



Available from stock

Call Gradus Technical Services for details of your nearest stockist



Secondary Barrier Matting Product Selection Guide

PRODUCT	SURFACE YARN	PAGE	WHERE TO USE BARRIER MATTING (See pages 12-13)		 FOOT TRAFFIC		
			ZONE 3	ZONE 4	HEAVY	MEDIUM	
Boulevard Stripe	Econyl® Regenerated SDN	46	✓ ³	✓	✓		
Boulevard 7000	100% SDN	48	✓ ³	✓	✓		
Boulevard 6000	Econyl® Regenerated SDN	50	✓	✓	✓		
Boulevard 5000	Econyl® Regenerated SDN	52	✓	✓	✓		
Boulevard 1500	100% Polypropylene	54	✓	✓		✓	

Notes:

¹Wear warranty. Warranty is subject to type of application, installation and on-going cleaning & maintenance being in accordance with Gradus recommendations. All Gradus Accessories warranties are subject to Gradus Accessories terms and conditions of sale which can be found at www.gradus.com

²Typical applications are a guide only. Attention should be paid to the performance characteristics of each mat type in conjunction with an assessment of the requirements of the particular application.

³Note - Boulevard Stripe & Boulevard 7000 are not recommended for use on staircases.

Secondary Barrier Matting

Boulevard secondary barrier matting is produced from high performance textiles and is ideal for use at internal entrances and access points as well as in high traffic circulation areas such as corridors and reception areas.

Secondary barrier matting is often used in conjunction with primary barrier matting or hybrid barrier matting to provide a total matting solution but in some circumstances can be used as a stand-alone mat.

	 MOISTURE & DIRT REMOVAL		CONSTRUCTION	TYPICAL APPLICATIONS ³	WARRANTY ²
	HIGH	MEDIUM			
	✓		Tufted Cut Pile	Used in conjunction with a primary or hybrid mat or as a stand-alone mat	5 Years
	✓		Tufted Cut Pile	Used in conjunction with a primary or hybrid mat or as a stand-alone mat. Also in lift lobbies, corridors and service areas	10 Years
	✓		Tufted Cut Pile	Used in conjunction with a primary or hybrid mat or as a stand-alone mat. Also in lift lobbies, corridors and service areas	10 Years
	✓		Tufted Cut Pile	Used in conjunction with a primary or hybrid mat or as a stand-alone mat. Also in lift lobbies, corridors and service areas	5 Years
		✓	Needlepunch	Used in conjunction with a primary or hybrid mat or as a stand-alone mat	5 Years

Boulevard™ Stripe



Zones 3 & 4:

Interior Circulation Areas, Some Interior Entrances & Access Points and Other Areas

Boulevard Stripe is constructed from ECONYL® regenerated solution dyed nylon yarn and incorporates a heavy scraper fibre for optimum dirt removal and moisture retention. The range is available in a choice of two colours in sheet format.

Boulevard Stripe can be used in conjunction with a primary entrance mat and in some situations can be used as stand-alone matting or in conjunction with a secondary barrier mat in entrances and access points.*

The range is designed to complement Boulevard 5000 secondary barrier matting, Mat-in-a-Box 5000 and Access 5000 hybrid barrier matting and Esplanade 5000 primary barrier matting.

Typical applications:

Used in conjunction with a primary mat or as a stand-alone mat



Product Information

See secondary matting product selection guide - **pages 44-45**



Warranties:	Sheet
Wear	5 Years

Specification:	Sheet
Product Dimensions	25m x 2m
Product Construction	Tufted Cut Pile
Surface Yarn	ECONYL® Regenerated SDN
Total Carpet Weight	4300 g/m ²
Tufted Pile Weight	800 g/m ²
Primary Backing	Non-woven
Secondary Backing	pvc
Total Carpet Thickness	9mm
Pile Height	5mm

Performance Specification	
Classification BS EN 1307	Class 3
Static Electricity ISO 6356	<2kV

Flammability	
BS EN 13501-1	Class Bfl-s1

For recommended adhesives contact Technical Services on 01625 428922.



* Note: Boulevard Stripe is not recommended for use on staircases

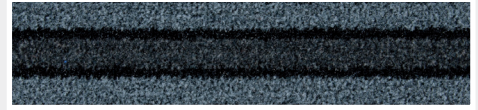

Magpie
LRV 3.85



Raven
LRV 2.48

Samples: An accurate colour match can only be achieved by requesting the relevant product sample(s) from Gradus Technical Services on 01625 428922.

Boulevard™ 7000



Zones 3 & 4:

Interior Circulation Areas, Some Interior Entrances & Access Points and Other Areas

Boulevard 7000 is constructed from 100% solution dyed nylon yarn and incorporates a heavy scraper fibre for optimum dirt removal and moisture retention. The range is available in a choice of four colours in sheet format.

Boulevard 7000 can be used in conjunction with a primary entrance mat and in some situations can be used as stand-alone matting in entrances and access points.*

Typical applications:

Used in conjunction with a primary mat or as a stand-alone mat. Also in lift lobbies, corridors and service areas



Product Information

See secondary matting product selection guide - **pages 44-45**



Heavy



High

Warranties:	Sheet
Wear	10 Years

Specification:	Sheet
Product Dimensions	+/- 20m x 2m
Product Construction	Tufted Cut Pile
Surface Yarn	100% Solution Dyed Nylon
Total Carpet Weight	+/- 3525 g/m ²
Tufted Pile Weight	+/- 825 g/m ²
Primary Backing	Non-woven Polyester/Polyamide
Secondary Backing	pvc
Total Carpet Thickness	+/- 8mm
Pile Height	+/- 6mm

Performance Specification	
Classification BS EN 1307	Class 33
Static Electricity ISO 6356	<2kV

Flammability	
BS EN 13501-1	Class Cfl-s1

For recommended adhesives contact Technical Services on 01625 428922.



* Note: Boulevard 7000 is not recommended for use on staircases

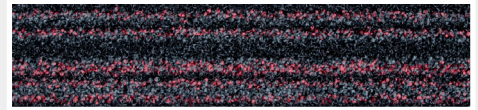

Red Oak
LRV 1.98

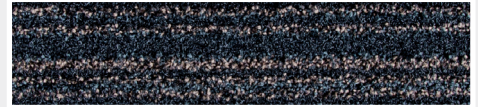

Hazelnut
LRV 2.37

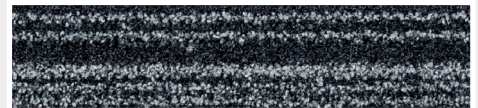

Gray Birch
LRV 5.60

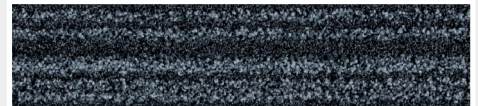

Black Ash
LRV 3.06

Samples: An accurate colour match can only be achieved by requesting the relevant product sample(s) from Gradus Technical Services on 01625 428922.

Boulevard™ 6000



Zones 3 & 4:

Interior Circulation Areas, Some Interior Entrances & Access Points and Other Areas

Boulevard 6000 is constructed from ECONYL® regenerated solution dyed nylon yarn and incorporates a heavy scraper fibre for optimum dirt removal and moisture retention. The range is available in a choice of eight colours in either sheet or tile format. Boulevard 6000 can be used in conjunction with a primary entrance mat and in some situations can be used as stand-alone matting in entrances and access points. The range is designed to complement Mat-in-a-Box 6000 and Access 6000 hybrid barrier matting and Esplanade 6000 primary barrier matting.

Typical applications:

Used in conjunction with a primary mat or as a stand-alone mat. Also in lift lobbies, corridors and service areas



Product Information

See secondary matting product selection guide - **pages 44-45**



Warranties:	Tile	Sheet
Wear	10 Years	10 Years

Specification:	Tile	Sheet
Product Dimensions	500mm x 500mm	25m x 2m
Product Construction	Tufted Cut Pile	
Surface Yarn	ECONYL® Regenerated SDN	
Total Carpet Weight	4750 g/m ²	4750 g/m ²
Tufted Pile Weight	950 g/m ²	950 g/m ²
Primary Backing	Non-woven	Non-woven
Secondary Backing	Bitumen	pvc
Total Carpet Thickness	9mm	8mm
Pile Height	5mm	5mm

Performance Specification	
Classification BS EN 1307	Class 3
Static Electricity ISO 6356	<2kV
Thermal Resistance BS 4745: 1990	1.3 (TOG)

Flammability		
BS EN 13501-1	Class Bfl-s1	Class Cfl-s1

For recommended adhesives contact Technical Services on 01625 428922.



Shadow
LRV 5.36

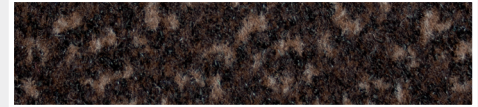

Walnut
LRV 2.86

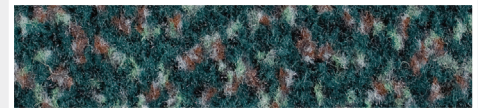

Rosemary
LRV 4.45

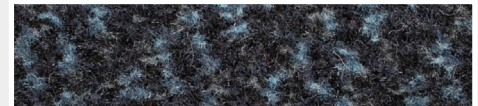

Galaxy
LRV 2.56



Indigo
LRV 4.01

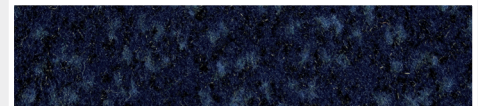

Atlantic
LRV 1.90

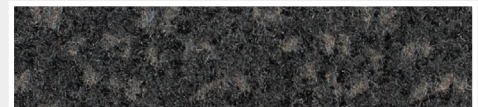

Nickel
LRV 3.70

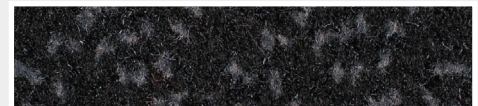

Nightfall
LRV 1.48

Samples: An accurate colour match can only be achieved by requesting the relevant product sample(s) from Gradus Technical Services on 01625 428922.

Boulevard™ 5000



Zones 3 & 4:

Interior Circulation Areas, Some Interior Entrances & Access Points and Other Areas

Boulevard 5000 is constructed from ECONYL® regenerated solution dyed nylon yarn and incorporates a light scraper fibre for optimum dirt removal and moisture retention. The range is available in a choice of nine colours in either sheet or tile format.

Boulevard 5000 can be used in conjunction with a primary entrance mat and in some situations can be used as stand-alone matting in entrances and access points.

The range is designed to complement Boulevard Stripe secondary barrier matting, Mat-in-a-Box 5000 and Access 5000 hybrid barrier matting and Esplanade 5000 primary barrier matting.

Typical applications:

Used in conjunction with a primary mat or as a stand-alone mat. Also in lift lobbies, corridors and service areas



Product Information

See secondary matting product selection guide - **pages 44-45**



Warranties:	Tile	Sheet
Wear	5 Years	5 Years

Specification:	Tile	Sheet
Product Dimensions	500mm x 500mm	25m x 2m
Product Construction	Tufted Cut Pile	
Surface Yarn	ECONYL® Regenerated SDN	
Total Carpet Weight	4600 g/m ²	4600 g/m ²
Tufted Pile Weight	800 g/m ²	800 g/m ²
Primary Backing	Non-woven	Non-woven
Secondary Backing	Bitumen	pvc
Total Carpet Thickness	8mm	7.5mm
Pile Height	5mm	5mm

Performance Specification	
Classification BS EN 1307	Class 3
Static Electricity ISO 6356	<2kV

Flammability		
BS EN 13501-1	Class Bfl-s1	Class Cfl-s1

For recommended adhesives contact Technical Services on 01625 428922.



The Dementia Services Development Centre at the University of Stirling have undertaken a review of the Gradus Boulevard 5000 range and have rated its design in relation to dementia design principles and it's usability within a dementia inclusive environment.

The following colours have been rated as class 1b – Corncrake, Cuckoo, Shelduck, Kestrel and can be used throughout dementia applications. We recommend a minimum contrast of 10 points LRV between adjacent floor finishes. Additional guidelines apply for the use of transition strips.

For further information please contact Gradus.



Corncrake
LRV 9.52

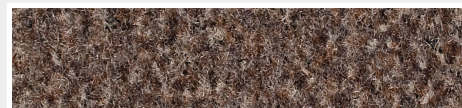

Kestrel
LRV 5.42



Shelduck
LRV 5.20

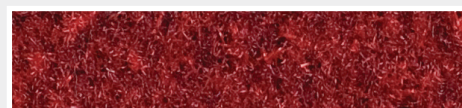

Redpoll
LRV 4.14



Cuckoo
LRV 5.63

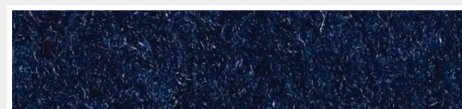

Swallow
LRV 2.08

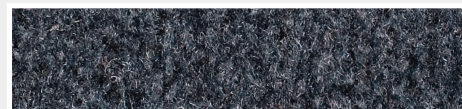

Moorhen
LRV 2.98

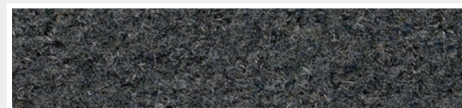

Falcon
LRV 5.11

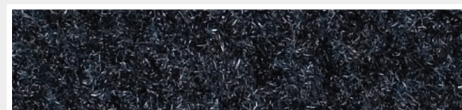

Jackdaw
LRV 1.73

Samples: An accurate colour match can only be achieved by requesting the relevant product sample(s) from Gradus Technical Services on 01625 428922.

Boulevard™ 1500



Zones 3 & 4:

Interior Circulation Areas, Some Interior Entrances & Access Points and Other Areas

Boulevard 1500 is constructed from 100% polypropylene yarn and is available in a choice of four colours in sheet format.

Boulevard 1500 can be used in conjunction with a primary entrance mat and in some situations can be used as stand-alone matting in entrances and access points.

The range is designed to complement Mat-in-a-Box 1550 hybrid barrier matting and Esplanade 1500 primary barrier matting.

Typical applications:

Used in conjunction with a primary mat or as a stand-alone mat



Product Information

See secondary matting product selection guide - **pages 44-45**



Warranties:	Sheet
Wear	5 Years

Specification:	Sheet
Product Dimensions	15m x 2m
Product Construction	Needlepunch
Surface Yarn	100% Polypropylene
Total Carpet Weight	3000 g/m ²
Tufted Pile Weight	1600 g/m ²
Backing	Rubber
Total Carpet Thickness	9mm

Performance Specification	
Static Electricity ISO 6356	<2kV

Flammability	
BS EN 13501-1	Class Efl

For recommended adhesives contact Technical Services on 01625 428922.

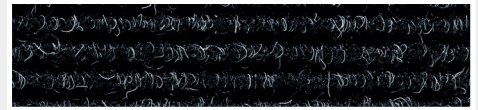

Tempestas
LRV 2.14

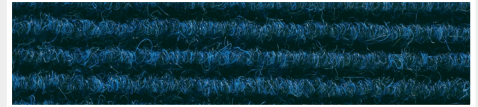

Marinus
LRV 2.71

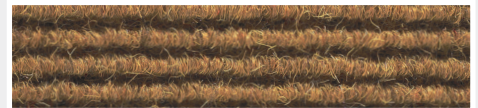

Terra
LRV 10.89

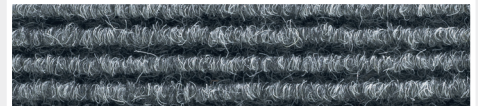

Calculus
LRV 9.03

Samples: An accurate colour match can only be achieved by requesting the relevant product sample(s) from Gradus Technical Services on 01625 428922.

Installation Accessories



Edging Strips

Edging strips are used for on-site trimming and to provide a neat finish at the raw edge of the mat. Edging strips are supplied with each order.

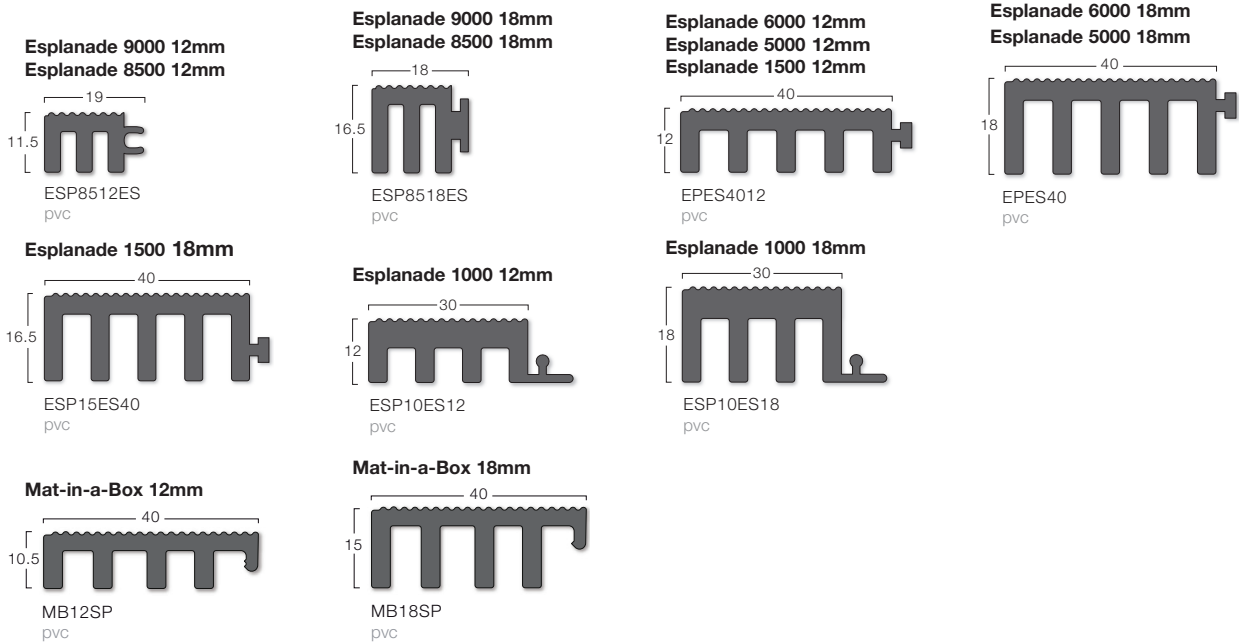

Expansion Strips

Expansion strips are supplied with Mat-in-a-Box to allow for minor movement and to provide a neat finish. Available in Black or Glacier (grey).

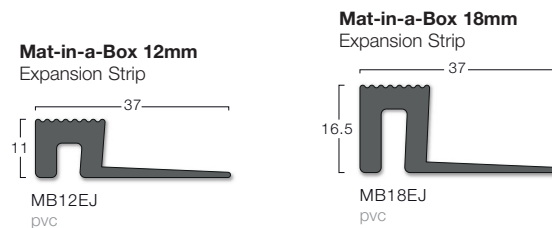

Spacer Strips

Spacer strips are supplied with Access & allow for minor movement within the mat and provide a neat finish at the raw edge of the mat. Spacer strips are supplied with each order. Available in Black or Grey.

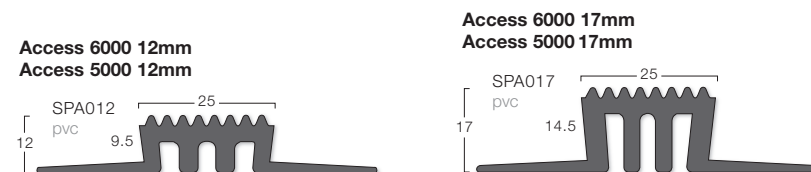

Divider Bars

Divider bars are used to achieve symmetrical design on mats exceeding two metres in width and are loose laid in line with the direction of traffic. Divider bars are supplied with each order.

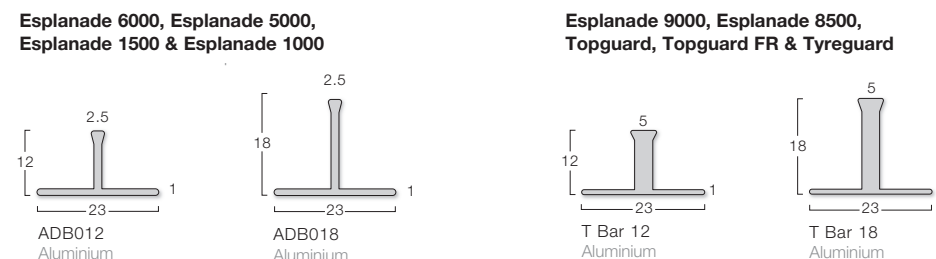

Push-in Hinge

Push-in hinges are used when installing Esplanade 6000 & Esplanade 5000 in restricted areas. Push-in hinges are supplied with each order.



Support Piece

Support pieces are used when installing Mat-in-a-Box 6000, Mat-in-a-Box 5000 and Mat-in-a-Box 1550. Support pieces are supplied with each order.

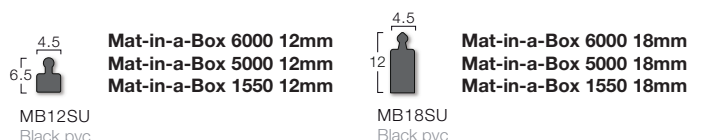

Profiles: Dimensions shown are nominal. Illustrations are 70% size in mm. Products subject to minor design alterations without notice.

Matting Accessories



Matwell Frames

Gradus offers a wide selection of matting accessories to ensure ease of installation.

Matwell frames and ramping strips provide a smooth and safe transition between a barrier mat and the adjoining floorcovering. This protects the edge of the mat from damage and prevents trip accidents caused by uneven flooring.

A choice of gauges is available to accommodate mat thicknesses of 12mm (recessed and surface-mounted), 18mm and 25mm (recessed only).

Matwell frames and ramping strips are offered either in stock lengths or as made-to-measure kits for individual mat specifications. Gradus' curving and fabrication capability allows for most mat shapes to be accommodated.

Recessed Matting

A recessed mat is installed into a matwell that has been set into an existing floor finish and fits flush with the surrounding floorcoverings. Matwell frames are used to protect and strengthen the matwell, protect the exposed edge of the floorcovering and provide safe transition to the surrounding area.

The base of the matwell is screeded to suit the required height of the mat and to provide a flat, sound surface (see Figures 1 & 2).

Note: Care must be taken when installing a mat to allow for door clearance.

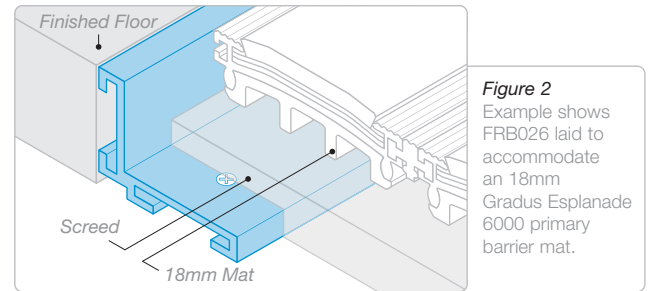
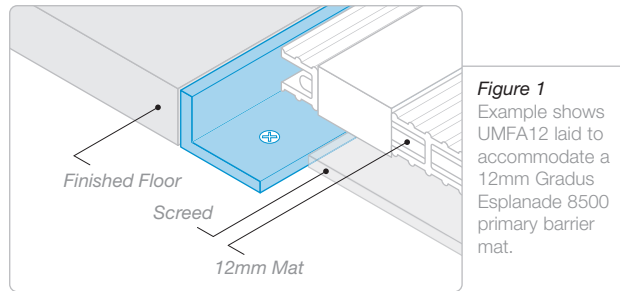

Recessed Frames

For use with Esplanade 9000, Esplanade 8500, Esplanade 6000, Esplanade 5000, Esplanade 1500, Esplanade 1000, Topguard, Topguard FR, Tyreguard, Access 6000 & Access 5000 matting, Mat-in-a-Box 6000, Mat-in-a-Box 5000 & Mat-in-a-Box 1550

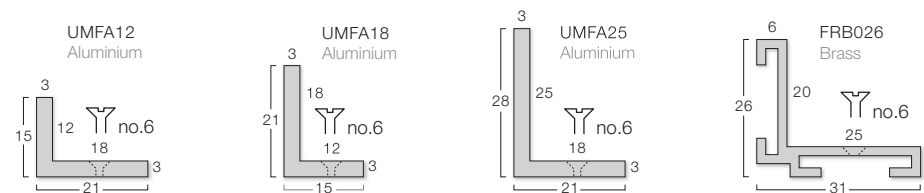

Note: UMFA12, UMFA18 & UMFA25 available in Mill Finish Aluminium or Black Anodised Aluminium. UMFA12 & UMFA18 also available in three Bronze Anodised Aluminium finishes.

Surface-Mounted Matting

A surface-mounted mat is loose-laid to a finished floor and sits proud of the surrounding floorcoverings. Ramping strips are provided to form a safe transition between the mat and the adjoining floor (see Figure 3).

Note: This type of installation should be avoided in areas subject to heavy trolley traffic. Care must be taken when installing a mat to allow for door clearance.

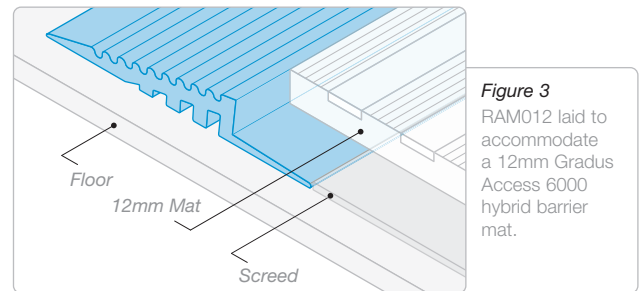

Ramping Frame

Creates a surface matwell. Mat is loose-laid on top of the floor. **Note:** Ramping frames cannot be curved.



Note: RAM012 for use with surface-mounted Access 6000 & Access 5000 & Mat-in-a-Box 6000, Mat-in-a-Box 5000 & Mat-in-a-Box 1550 12mm. Available in Black and Grey

Profiles: Dimensions shown are nominal. Illustrations are 70% size in mm. Products subject to minor design alterations without notice.

Matwell Frames

Formable Frames

ETR trims allow design flexibility where a formed matwell frame is required. ETR trims are available in aluminium and brass and are suitable for use with the majority of Gradus primary barrier matting.

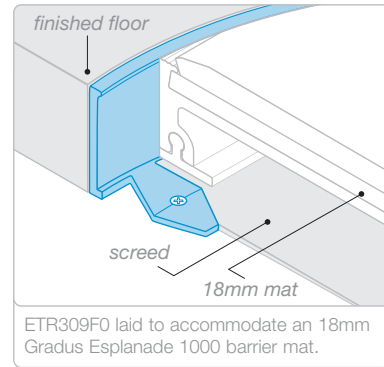
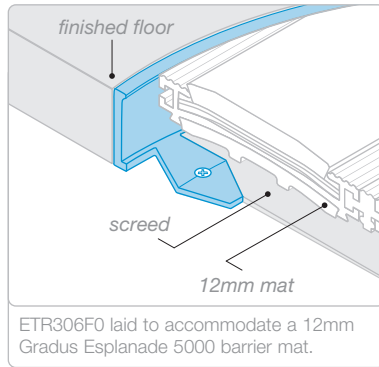
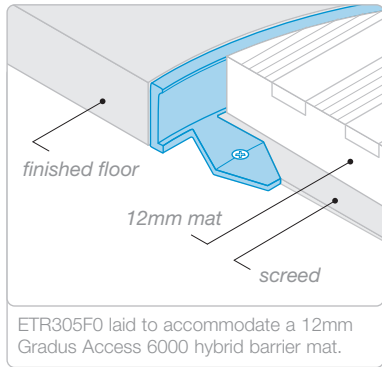

Key

- Supplied pre-punched with tabs and fixing holes for on-site curving.
- Can be curved on-site by hand.

CODE / PROFILE	MATERIAL	LENGTH	COLOURS / FINISHES
ETR305F0 	Aluminium	2.50m	F0 Natural
ETR306F0 	Aluminium	2.50m	F0 Natural
ETR312F0 	Aluminium	2.50m	F0 Natural
ETR309F0 	Aluminium	2.50m	F0 Natural
ETR305F7 	Brass	2.50m	F7 Polished
ETR306F7 	Brass	2.50m	F7 Polished
ETR309F7 	Brass	2.50m	F7 Polished

Dimensions shown are nominal. Illustrations are 70% size in mm. Products subject to minor design alterations without notice.

Brass ETR trims are subject to minimum order and lead times. Contact Technical Support on 01625 428922 for details.

Transition Profiles

Trans-Edge®

Trans-Edge carpet trims provide a safe transition between Boulevard secondary barrier matting and floorcoverings of the same or different heights. For use in the most demanding environments, where frequent heavy foot and trolley traffic can be expected eg. railway stations, airports, transport interchanges, department stores and hospitals.

Trans-Edge trims comprise an aluminium base channel with a choice of slip-resistant Elite inserts. Standard interior insert is available for interior dry conditions. Xtra-grip insert is available for interior areas that are at risk of becoming wet and therefore pose a higher risk of slip. For further details visit www.gradus.com

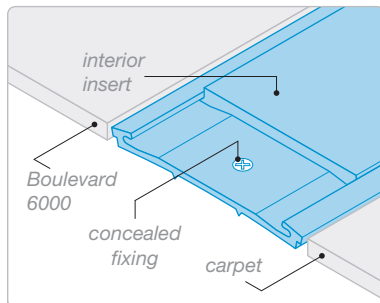

Typical example: ELACS5040 Boulevard 6000 barrier matting to carpet.

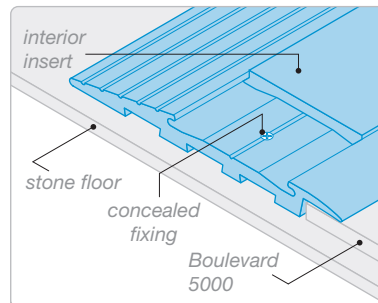

Typical example: ELAR830 stone floor to Boulevard 5000 barrier matting.

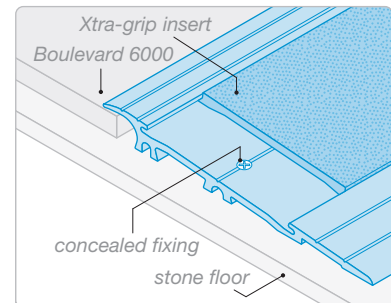

Typical example: ELAR950 stone floor to Boulevard 6000 barrier matting.

CODE / PROFILE	MATERIAL	LENGTH	COLOURS / FINISHES
ELACS5040 	Aluminium PVC-u insert (ELINS40)	2.50m Insert: 25m coil	Available in a choice of 16 interior insert colours. Visit www.gradus.com for further details
ELAR830 	Aluminium PVC-u insert (ELINS30 or ELINSXG30)	2.50m Inserts: 15m coils	Available in a choice of 4 Xtra-grip and 5 interior insert colours. Visit www.gradus.com for further details
ELAR950 	Aluminium PVC-u insert (ELINS50 or ELINSXG50)	2.50m ELINS50: 25m coil ELINSXG50: 15m coil	Available in a choice of 4 Xtra-grip and 16 interior insert colours. Visit www.gradus.com for further details
ELAR1250 	Aluminium PVC-u insert (ELINS50 or ELINSXG50)	2.50m ELINS50: 25m coil ELINSXG50: 15m coil	Available in a choice of 4 Xtra-grip and 16 interior insert colours. Visit www.gradus.com for further details

Dimensions shown are nominal. Illustrations are 70% size in mm. Products subject to minor design alterations without notice.

Transition Profiles



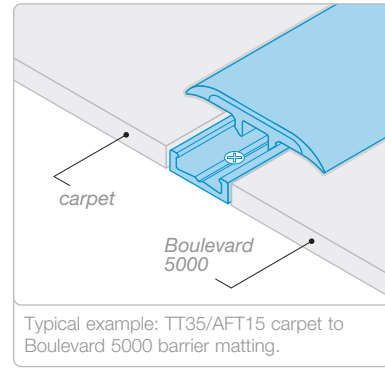
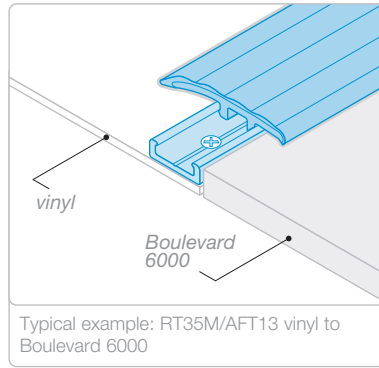
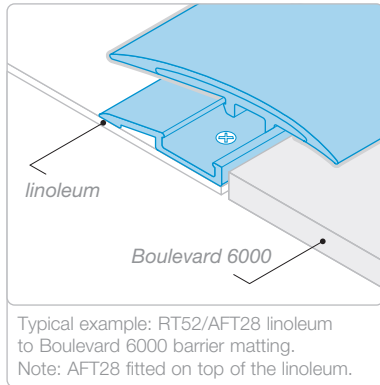

Clip-Top™

Clip-Top trims provide a neat, safe transition between Boulevard secondary barrier matting and floorcoverings of the same or different heights. This two-piece product comprises PVC-u tops, which can be replaced so that the colour can be altered as part of a refurbishment programme, or if a worn or damaged section needs to be changed, without renewing the base or disrupting the fitted floorcovering.

Available in a choice of colours to suit most interior design schemes. A selection of Clip-Top products are shown below. For more information visit www.gradus.com

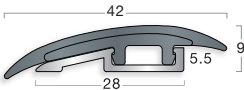
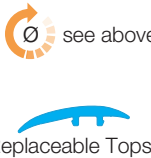
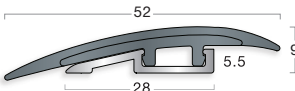
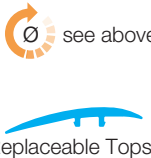
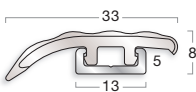

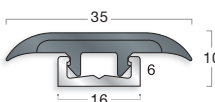
 A number of PVC-u/metallic PVC-u tops and aluminium bases can be factory fabricated to a radius shape, subject to approval of template or detailed drawing (showing radius details)

CODE / PROFILE	MATERIAL	LENGTH	COLOURS / FINISHES
RT42 / AFT28 Registered Community Design Application No 001201941  	PVC-u Top Aluminium Base	2.50m	<ul style="list-style-type: none"> Black Brown Granite Bluebell Fawn Dove Clay
RT52 / AFT28 Registered Community Design Application No 001201941  	PVC-u Top Aluminium Base	2.50m	<ul style="list-style-type: none"> Black Brown Granite Bluebell Fawn Dove Clay
RT35M / AFT13  	Metallic PVC-u Top Aluminium Base	2.50m	<ul style="list-style-type: none"> Burnt Almond Zinc Doublebloom Platinum Silver
TT35 / AFT15 Registered Community Design Application No 001201941  	PVC-u Top Aluminium Base	2.50m	<ul style="list-style-type: none"> Black Brown Granite Bluebell Fawn Dove Clay

Dimensions shown are nominal. Illustrations are 70% size in mm. Products subject to minor design alterations without notice.

Transition Profiles

Clip-Top fx®

Clip-Top fx trims provide a neat, safe transition between Boulevard secondary barrier matting and floorcoverings of the same or different heights. This two-piece product comprises PVC-u tops and a choice of bases: PVC-u for curves and aluminium for straights. The product can be easily formed on-site without the need for heat application, reducing the requirements for pre-fabricated curves. The tops can be replaced so that the colour can be altered as part of a refurbishment programme, or if a worn or damaged section needs to be changed, without renewing the base or disrupting the fitted floorcovering.

Available in a choice of 6 colours to suit most interior design schemes. For more information visit www.gradus.com

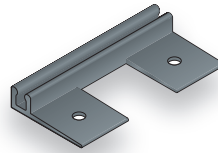

PVC-u bases are pre-punched with tabs and fixing holes for on-site curving. Latex screed should be used with resilient floorcoverings to prevent pre-punched base shadowing through.

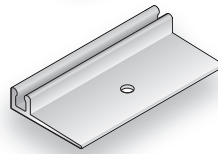

Aluminium bases have a solid flange for straight lengths.

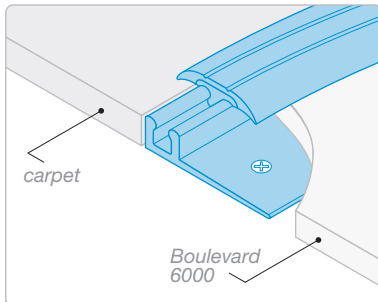

Typical example: FXT21/FXB336 carpet to Boulevard 6000 barrier matting.

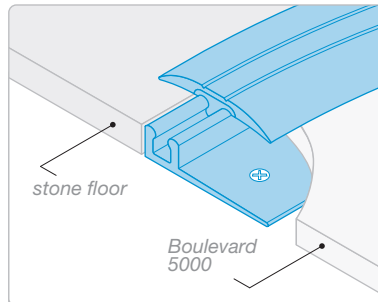

Typical example: FXT31/FXB336 stone floor to Boulevard 5000 barrier matting.

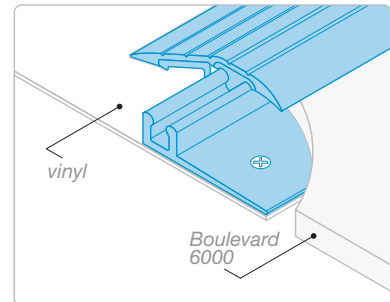

Typical example: FXR40/AFT336 vinyl to Boulevard 6000 barrier matting.



Can be easily formed on site without the need for heat application when used with PVC-u bases. See individual profiles for curving radii.

CODE / PROFILE	MATERIAL	LENGTH	COLOURS / FINISHES	
FXT21 / FXB336 	400mm min curve on-site Replaceable Tops	PVC-u Top PVC-u Base	2.50m	<ul style="list-style-type: none"> Black Brown Granite Bluebell Fawn Dove Clay
FXT31 / FXB336 	400mm min curve on-site Replaceable Tops	PVC-u Top PVC-u Base	2.50m	<ul style="list-style-type: none"> Black Brown Granite Bluebell Fawn Dove Clay
FXR40 / AFT336 	Replaceable Tops	PVC-u Top Aluminium Base	2.50m	<ul style="list-style-type: none"> Black Brown Granite Bluebell Fawn Dove Clay

Dimensions shown are nominal. Illustrations are 70% size in mm. Products subject to minor design alterations without notice.

Manufacturing



- All Gradus barrier matting systems are manufactured to the highest standards using only the best materials available
- Meet the requirements of the application for which they are intended
- Extensively tested to give superior performance throughout their life
- Dedicated manufacturing facility allows flexibility and the ability to respond to customer needs, ensuring the right product is delivered every time
- Manufactured to ISO 9001, all Gradus products are supported by the dedicated technical support service
- Most products can be pre-shaped in the factory (subject to approval of a suitable template) and delivered for an 'easy fit' on-site

5 Day Manufacturing Service

Available for Esplanade 9000, Esplanade 8500, Esplanade 6000, Esplanade 5000, Esplanade 1500, Esplanade 1000, Topguard, Topguard Plain, Tyreguard, Access 6000, Access 5000, Mat-in-a-Box 6000 & Mat-in-a-Box 5000 on all orders up to 20m²



Please note the following exclusions/conditions apply:

1. 5 day matting service refers to the production time for manufacture i.e. goods will be available for dispatch within 5 working days
2. 5 day lead time applies upon receipt of purchase order and all information required to commence manufacture
3. Delivery times vary and in some circumstances will incur a charge
4. Excludes shaped and/or logo mats
5. 5 day manufacturing lead time is subject to stock availability

Project Management & Installation



- Gradus offers a complete supply and fit package, ensuring a convenient and reliable service throughout the specification, survey and installation process
- Specially trained specification consultants can provide face to face advice when specifying matting, ensuring that the product selected is matched to the exact requirements of the building
- All types of installation, including the most complex shapes and fabrications, can be undertaken by expert installation teams
- Covers all aspects of the installation including matwell repair, templating, shaping on-site, installation and handover
- Gradus Contracts manages the entire process to tailor the order to specific customer requirements
- To take advantage of the Supply and Fit Service, contact Gradus' specification consultants who will undertake an evaluation of the requirements from which a detailed quotation can be prepared. Details of specification consultants are available from Technical Support on 01625 428922 (UK only)

Specification Guidelines

Factors to consider when specifying a mat

Ensuring the safety of visitors and staff at a building entrance is critical in making a positive first impression.

To help prevent slip, trip and fall accidents, the entrance flooring should not present a hazard to the user in normal use and should not become slippery when wet. With the main source of wet contamination at entrances being water carried on footwear and tyres of wheeled traffic, a suitable entrance matting system is vital in removing and retaining moisture to stop it being transferred to internal floorcoverings.

A study of pedestrian flow rates at entrances has been undertaken by the Health & Safety Laboratory (HSL) and the Entrance Flooring Systems Association (EFSA), simulating the use of entrance matting to quantify water removal using a laboratory test method developed by EFSA. The findings showed six main points should be considered when choosing an entrance matting system.

Peak Flow Rate

Also known as 'volume of traffic', the peak flow rate predicts the concentration of traffic and identifies the key times of day when people enter or exit the building.

Example 1: School

- Two main times of day when a heavy concentration of traffic enter or exit the building
- Specification - heavy duty mat to cope with a high flow rate

Example 2: High Street Shop

- Consistent flow of traffic
- Specification - Secondary barrier matting used in conjunction with a primary mat to increase moisture removal

The provision of overhead heaters can also help with the evaporation of moisture to speed up the drying time of the mat.



Peak Flow Rate

Width of Matting

Matting should cover the entire entrance of a building, including any side entrances.

As the first point of contact and, therefore, the first opportunity to stop dirt and moisture being tracked into any building, traffic should not be able to avoid the entrance matting.

In some instances certain entrances are favoured, i.e. those close to toilets, canteen areas or entrances that have automatic doors, so it is important to ensure all access points are covered.

A larger quantity of matting at the favoured entrances is advised in these circumstances to guarantee an adequate amount of matting is provided to cope with the level of traffic.



Width of Matting

Length of Matting

HSL and EFSA have provided guidelines on the length of matting that should be installed based on the number of people entering a building per hour:

Flow Rate	People Per Hour	Minimum Length
Low	78	3-4 metres
Medium	400	6-7 metres
High	800	8-10 metres

Fitting the recommended amount of matting may not always be possible and small premises, such as a high street travel agent, may only be able to accommodate a small primary entrance mat.

Using barrier matting as a floorcovering to support the entrance mat provides an ideal solution in these situations to increase dirt and moisture removal.

It is crucial to specify enough matting from the outset as modifying the entrance can be costly once the mat / matwell are installed.

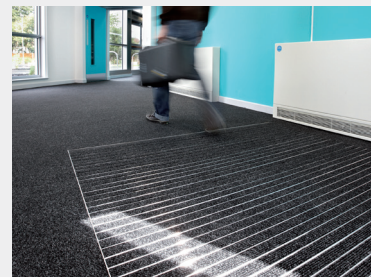

Length of Matting

Environmental Factors

The external environment has an impact on the matting that is selected e.g.

- Does the entrance come straight off the street?
- Is there a canopy to shield the entrance from elements such as wind and rain?

If not, more thought should be given to specifying a more heavy duty entrance mat that will be able to cope with harsher levels of dirt and moisture ingress.

If under-specified, the mat will soon become saturated and unable to retain any more moisture and as a result these contaminants would be tracked onto surrounding floorcoverings, increasing the risk of slip, trip and fall accidents.



Environmental Factors

Type of Traffic

Matting should be suitable for both foot and wheeled traffic to meet the latest guidelines (see pages 66-69).

It is the level of each type of traffic, however, that needs to be considered to provide the optimum specification for the environment.

Example 1: Office

- The majority of traffic is likely to be pedestrian with a low volume of wheeled traffic

Example 2: Supermarket

- A high concentration of both wheeled and foot traffic would be expected



Type of Traffic

Sustainability

Sustainability is now a key factor for consideration in all building design.

Products that support the environment, such as those with a high recycled content or those that have a high BREEAM rating, are favoured over those that are not as environmentally friendly.

Gradus Boulevard 6000 barrier matting has been BRE certified whilst Tyreguard primary matting incorporates 100% recycled wipers made from aeroplane tyres.



Sustainability

The study also highlighted some common errors when specifying matting, which can be detrimental to an installation. To ensure the optimum specification:

- ✗ **DON'T** use throw down mats
- ✗ **DON'T** leave a gap between the entrance and the matting
- ✗ **DON'T** use mats that impede the movement of wheelchairs (or other wheeled vehicles), i.e. Coir
- ✗ **DON'T** forget to clean the mat to maintain its effectiveness

Specification Guidelines

The Building Regulations and British Standards specifying the right Gradus product

The Building Regulations and British Standards are designed to ensure the optimum specification of products through a combination of legislative requirements and guidance. The following extracts have been taken from The Building Regulations 2010 and British Standards BS 7953:1999, BS 8300-2:2018 and BS 9266:2013 to show how Gradus products can be used to help satisfy these requirements, and help achieve an inclusive environment in line with the Equality Act 2010. For further details on this or any other aspect of The Building Regulations and British Standards contact Gradus Technical Support on 01625 428922.

Note: Details of standards and guidelines are correct at time of going to print. Current standards should be checked prior to specifying.

The Building Regulations 2010 - Approved Document M “Access to and use of buildings”

(2015 edition incorporating 2016 amendments – for use in England)

The latest version of Approved Document M 2015 is stated ‘for use in England’. Current building standards should be checked at time of specification for Wales, Scotland and Northern Ireland.

Approved Document M is split into two parts:

- Volume 1: Dwellings
- Volume 2: Buildings other than dwellings

The below abstracts of guidance are taken from Volume 2.

Approved documents are intended to provide guidance and much of the guidance in Approved Document M is based on BS 8300. The guidance contained in Approved Document M is designed to indicate one way in which requirements may be met. There may be other equally satisfactory ways of meeting the requirements. The main points relating to entrance matting detailed in Approved Document M are shown below, with supporting recommendations by Gradus [shown in blue text](#).

The Legal Requirement

Part M Access to and use of buildings Access and Use

M1. Reasonable provision shall be made for people to -

- a) gain access to, and
- b) use the building and its facilities

Entrance Lobbies

2.29 (e) Floor surface materials within the lobby do not impede the movement of wheelchairs e.g. not coir matting, and changes in floor materials do not create a potential trip hazard.

[All Gradus barrier matting featured within this catalogue is suitable for use with wheelchairs.](#)

2.29 (f) The floor surface helps to remove rainwater from shoes and wheelchairs.

[A combination of Gradus primary matting and secondary barrier matting will help prevent the ingress of rainwater.](#)

2.29 (g) Where matwells are provided, the surface of the mat is level with the surface of the adjacent floor finish.

[Gradus offers a range of matwell frames and primary barrier mats designed to work together to provide a smooth transition to the surrounding floor finish.](#)

*Source: Building Regulations - Access to and use of buildings - Approved Document M - 2015 Edition. Crown Copyright
You may reuse this information (excluding logos) free of charge in any format or medium under the terms of the Open Government Licence v3. To view this licence visit www.nationalarchives.gov.uk/doc/open-government-licence/version/3/*

BS 7953:1999

Entrance flooring systems - Selection, installation and maintenance

This British Standard describes types of interior and exterior entrance flooring systems and gives recommendations for methods of selection, planning, installation and maintenance. Gradus' advice and recommendations are shown in [blue text](#).

The function of the entrance flooring system is to reduce the incidence of slip accidents by reducing the amount of soil and moisture tracked onto hard and resilient floors... an entrance flooring system should have the following qualities:

- removal and retention of soil;
- ease of cleaning and maintenance;
- retention of physical characteristics

[Gradus Barrier Matting Systems effectively remove soil and moisture from both foot and wheeled traffic. The design and materials used within Gradus matting ensure that the products can be easily cleaned and maintained.](#)

Permission to reproduce extracts from BS 7953: 1999 is granted by BSI Standards Limited (BSI). No other use of this material is permitted. British Standards can be obtained in PDF or hard copy formats from the BSI online shop: www.bsigroup.com/Shop

BS 8300-2:2018

Design of an accessible and inclusive built environment Part 2: Buildings - Code of practice

This standard provides guidance or good practice in the design of non-domestic buildings - Everyone, including disabled and older people with particular access requirements, should be able to enter, use and leave a building easily, comfortably and independently, including being able to escape in the event of fire or other emergency. Gradus' advice and recommendations are shown in [blue text](#).

[Gradus Barrier Matting Systems effectively remove soil and moisture from both foot and wheeled traffic. The design and materials used within Gradus matting ensure that the products can be easily cleaned and maintained.](#)

Entrances

8.1.1 General

Unless suitably designed, the entrance to a building can often be a barrier to access. The following factors should be addressed in the design of the entrance to a building:

- a) the prominence and visual relationship of the entrance with its surroundings both internally and externally.
- b) the type of threshold needed to allow safe and step-free access.

8.6.1 Entrance flooring systems

At entrances to commercial buildings and buildings used by the general public, a suitable entrance flooring system to remove water and debris from the soles of shoes and wheelchair wheels should be provided, taking account of the volume of pedestrian flow and the distance required to accommodate the circumference of a large wheelchair wheel (a minimum of 2000mm).

Matting and other floor surfaces should conform to the recommendations in 11.3.

NOTE 1 Guidance on the selection, planning, installation and maintenance of entrance flooring systems is given in BS 7953.

[Useful products: Entrances are prone to heavy soiling and moisture ingress, which should be removed at the access points to a building to increase life expectancy and reduce maintenance costs of the adjacent floorcovering.](#)

[Combinations of exterior and interior primary matting and secondary barrier matting can be installed to provide attractive, functional barrier solutions that ensure adequate removal of both tracked in dirt and moisture. Gradus offers a range of primary mats \(Esplanade 9000, Esplanade 8500, Esplanade 6000, Esplanade 5000, Esplanade 1500, Esplanade 1000, Topguard, Topguard FR, Tyreguard, Access 6000, Access 5000, Mat-in-a-Box 6000, Mat-in-a-Box 5000 & Mat-in-a-Box 1550\) that can be used in conjunction with secondary barrier matting \(Boulevard 1500, Boulevard 5000, Boulevard 6000, Boulevard 7000 & Boulevard Stripe\) to fulfil this requirement.](#)

Continued...

Reception Areas / Foyers

8.6.2 Reception area

Floor surfaces within reception areas should be free from obstructions, have a firm, slip-resistant surface (see Annex C) and allow easy manoeuvre of a wheelchair.

Useful products: Foyers and reception areas are typically heavily trafficked circulation areas, often located near the entrance to buildings. They require hard-wearing floorcoverings that are easy to clean and will retain their appearance, in order to ensure that important first impressions are made. Products from the Boulevard range provide an ideal solution.

Corridors / Passageways

9.1 Corridors and passageways

Choosing appropriate floor, wall and ceiling materials that contrast visually with adjacent surfaces, and careful use of natural and artificial lighting, will benefit people who are blind or partially sighted and people with sensory/neurological processing difficulties.

9.1.3 Floors in corridors

Floor patterning that could be mistaken for steps, e.g. stripes, should not be used for floors in corridors.

Useful products: Main circulation areas, such as corridors, are often exposed to high and frequent levels of footfall. The introduction of a secondary barrier mat such as Boulevard will increase life expectancy and reduce wear and maintenance of surrounding floor finishes.

General

11.1 Visual characteristics

The LRV of a wall should be 30 points different from that of the ceiling and of the floor.

11.3 Floor surfaces

Very shiny surfaces should be avoided due to problems with glare and the fact that they are perceived as being slippery even when they have a slip-resistant surface.

Large, repeating patterns that incorporate bold contrasting colours or simulate steps should not be used for any floor surface.

NOTE 1 People who are blind or partially sighted, and people with sensory/neurological processing difficulties, can be confused by bold patterns used in floor coverings and might read them as changes in level.

Floor surfaces should offer a level of slip resistance that provides a firm foothold and good wheel grip under normal conditions of use. Adjacent floor surfaces should have similar levels of slip resistance.

The ingress of soil and surface moisture to buildings, or their transfer between adjacent internal areas, should be reduced to the lowest practicable level, e.g. through the use of appropriate entrance flooring systems, conforming to BS 7953 (see also 8.6.1).

Any matting should either have its surface level with the adjacent floor finish or, if surface laid, be of a type that has a rubber backing and chamfered edges. If, in exceptional circumstances other types of surface laid mats are used, they should be securely fixed to the floor at their edges and at any joints, to avoid the risk of tripping or slipping.

At wheelchair turning points and other heavily used areas other than entrances where entrance flooring systems are in use, carpet should be securely fixed on firm backing. Carpet construction, pile height and underlay type should be taken into account when assessing the suitability for wheelchair users and for people using walking sticks or frames.

Deep pile carpets and coir matting on the surface of the floor or within a mat well should not be used.

Permission to reproduce extracts from BS 8300-2:2018 is granted by BSI Standards Limited (BSI). No other use of this material is permitted. British Standards can be obtained in PDF or hard copy formats from the BSI online shop: www.bsigroup.com/Shop

Design of accessible and adaptable general needs housing - Code of practice

The requirements of a dwelling's occupants can change as a result of accident, illness or ageing, giving rise to reduced mobility or increasing sensory loss. In order to meet these changing requirements, homes need to be accessible and adaptable; accessible for both visitors and residents and adaptable to meet residents' changing needs both temporary and longer term.

This standard outlines recommendations for design features which can be incorporated when the dwelling is first built, or have provision made at the outset for their future adaptation. This helps reduce the need for expensive or disruptive alterations or substantial adaptations in the future.

Extracts of BS 9266:2013 are reproduced below with Gradus' advice and recommendations shown in blue text.

Guidance on entrance matting

7 Entrances to individual houses or blocks of flats

7.8 Entrance matting in blocks of flats

A communal entrance lobby of a block of flats should have an entrance flooring system to help collect water and debris from the soles of shoes, etc. To minimize the risk of slips, trips and falls, any matting should either have its surface level with the adjacent floor finish or, if surface laid, be of a type that has a slip-resistant backing and chamfered edges.

Note Guidance on the selection, planning, installation and maintenance of entrance flooring systems is given in BS 7953.

Gradus offers a range of matwell frames and primary barrier mats designed to work together to provide a smooth transition to the surrounding floor finish.

Useful products: Entrances are prone to heavy soiling and moisture ingress, which should be removed at the access points to a building to increase life expectancy and reduce maintenance costs of the adjacent floorcovering. Combinations of exterior and interior primary matting and secondary barrier matting can be installed to provide attractive, functional barrier solutions that ensure adequate removal of both tracked in dirt and moisture. Gradus offers a range of primary mats (Esplanade 9000, Esplanade 8500, Esplanade 6000, Esplanade 5000, Esplanade 1500, Esplanade 1000, Topguard, Topguard FR, Tyreguard, Access 6000, Access 5000, Mat-in-a-Box 6000, Mat-in-a-Box 5000 & Mat-in-a-Box 1550) that can be used in conjunction with secondary barrier matting (Boulevard 1500, Boulevard 5000, Boulevard 6000, Boulevard 7000 and Boulevard Stripe) to fulfil this requirement.

Permission to reproduce extracts from BS 9266:2013 is granted by BSI Standards Limited (BSI). No other use of this material is permitted. British Standards can be obtained in PDF or hard copy formats from the BSI online shop: www.bsigroup.com/Shop

See through their eyes

Dementia designs on demand

We know that designing for people living with dementia is not easy, so we have developed a comprehensive design tool that will help you to create a safer environment for independent living.

The App helps specifiers through the design process by ensuring that their projects consider Inclusive Dementia Design to promote independent living.

Products include:

Carpet and vinyl, entrance matting, floor trims, skirtings, wall protection & handrails and stair edgings.

Book a design session with our specialist team:

Call: 0808 196 5640 or

Visit: www.gradus.com/inclusive-dementia-design



Cleaning & Maintenance Guidelines



A planned cleaning and maintenance programme is crucial to help maintain the performance and visual appearance of Gradus barrier matting and to maximise the lifespan of the product. Trained cleaning staff or a reputable contract cleaner should be used.

Daily Cleaning

Sweep and vacuum daily to remove surface soil using a heavy duty upright vacuum cleaner with a brush or tub vacuum cleaner with a power head. Inspect for chewing gum and remove as necessary (see **chewing gum removal** for more information).

If the matting is wet, the area should be vacuumed using a wet pick up machine to remove as much water / soil as possible.

Deep Cleaning

To maintain a good visible standard, the matting will require deep cleaning on a weekly / monthly / as required basis (depending on weather conditions and volume of traffic). Deep cleaning can be carried out using various methods, depending on equipment availability.

In all cases, deep cleaning must follow brushing and vacuuming. Attention must be given to stains by using a pre-treatment of carpet spot and stain remover and chewing gum remover if required.

- A) Preferred Method: The use of a conventional jet extraction machine, using a conventional floor tool, scrubbing the carpet and continuing to extract as much water as possible. This method leaves the carpet as dry as possible.
- B) Deep Soiled Matting: As with all other maintenance methods, always prepare the carpet by vacuum cleaning prior to treatment. The cleaning professional may consider a combination of a rotary scrubbing machine fitted with a carpet brush and extraction equipment to get improved results.

Recommended Cleaning Products

Gradus has worked with Selden Research to undertake extensive testing on Gradus barrier matting products. As a result, a range of cleaning products has been recommended for use with Gradus matting.

Chewing Gum Removal

Chewing gum can be removed by applying a suitable chewing gum remover. Lightly spray onto the affected area and allow the product to take effect. Scrape off with a blunt object such as a spatula.

For further information about these cleaning products, including instructions for use and COSHH data sheets, please contact:

Selden Research Limited, Staden Business Park, Staden Lane, Buxton, Derbyshire, SK17 9RZ.
Tel: 01298 26226 Email: gradus@selden.co.uk Website: www.selden.co.uk

The GRADUS Knowledge

CPD



A full range of RIBA assessed CPD seminars available covering specification, legislation, safety, performance and aesthetics. Gradus is one of the original members of the RIBA CPD Providers Network and currently offers a full range of RIBA assessed and approved CPD seminars covering:

- The Specification & Design Considerations of Barrier Matting Systems
- The Specification & Design Considerations of Stair Edgings
- The Specification & Design Considerations of Wall, Corner & Door Protection Systems

All seminars are part of the RIBA core curriculum syllabus and earn double CPD points for those attending the seminars. For further information contact Gradus Technical Support on 01625 428922 or use the Contact Us form on our website.

Seminar



The Gradus Knowledge seminar is an informal opportunity for Gradus to bring an exhibition of products directly to you.

We have designed them to be flexible and informative and they can be arranged at a time and date to suit you. They typically last around 2 hours and in this time people drop in as they wish. Gradus personnel are available to discuss our products generally or address specific requirements.

They are often booked over lunch time and we are happy to work with you to provide lunch or if you prefer a different time, a variety of snacks.

Call to book your Gradus Knowledge seminar on 0800 021 4534 or email: imail@gradus.com

Gerflor[®]
theflooringgroup

GRADUS
A Gerflor company

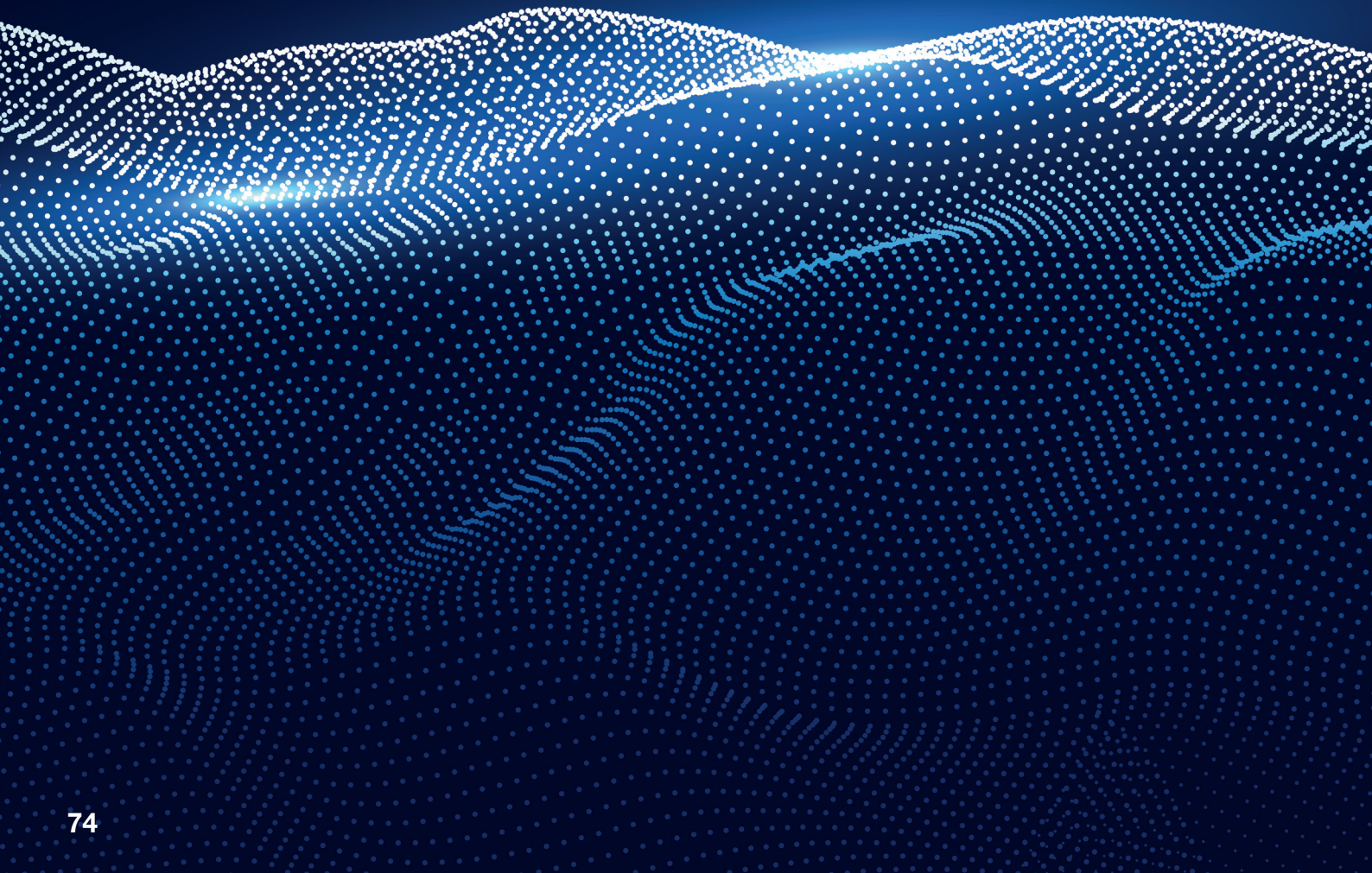

FUNDAMENTALS

A **FUSION** OF PRODUCTS & VALUES

Gerflor and Gradus offer products which are ideal for use in a wide variety of applications including healthcare, commercial office, education, retail, hospitality & leisure and housing. Products can be combined to provide a complete package that balances performance, aesthetics and cost alongside environmentally responsible manufacturing processes.

A **FRESH** APPROACH

We believe passionately in providing the customer with the very best in terms of service. Through our combined team we can offer expert advice to help with product selection backed up with extensive UK stocks to ensure our products are delivered on-time, every-time.

A NEW LEVEL
OF INNOVATION,
QUALITY, SERVICE
& TEAMWORK



STAIR EDGINGS
FLOOR TRIMS
MATTING
WALL PROTECTION
LIGHTING

NEXT DAY SERVICE
PRODUCT EXPERTISE
WARRANTY
SUSTAINABILITY





CREATION LVT
 TARASAFE
 TARAFLEX
 TECHNICAL TILES
 CARPETS



HOUSING
 RETAIL
 HOSPITALITY
 TRANSPORT



EDUCATION
 HEALTHCARE
 COMMERCIAL OFFICE
 SPORTS

GRADUS

Gradus Accessories Park Green Macclesfield Cheshire SK11 7LZ

For enquiries outside the UK and Eire contact Gradus International on +44 (0)1625 613780

Gradus International
England

Tel +44 (0) 1625 613780

Gradus Far East
Singapore

Tel: (+65) 6734 5933

call: 01625 428922

gradus.com

This catalogue supersedes and replaces all previous issues.

All designs, images and illustrations contained within this catalogue remain the copyright of Gradus Ltd.©

All trademarks, product names and codes detailed within this catalogue are the property of Gradus Ltd.